

# USER AND MAINTENANCE MANUAL



# Introduction

---

Småland quality since 1924!

In today's society, more and more demands are being placed on buildings to ensure that we can live safely and securely, healthily, in an energy efficient manner & sustainably. We supply quality products that fulfil these requirements. This document describes the functions of the products and how to maintain them.



# Table of contents

## 1. User manual

1.1 Pivot hung windows.....	2
1.2 Window products with Tilt-Turn fittings .....	4
1.2.1 Malfunction catch	
1.3 Switching function inward 2+1 casement.....	6
1.4 Switching function outward-opening 2+1 French .	7
1.5 Bottom hung windows .....	8
1.6 Handling of the passiv part on double doors or windows with mullions .....	9
1.6.1 Outward opening double doors and windows with flush-bolts	
1.6.2 Inward-opening	
1.7 Internally visible espagnolette.....	11
1.8 Brake.....	12
1.9 Child safety fittings.....	13
1.9.1 Handle blocking latch KISI2	
1.9.2 Restrictor Assa 184	
1.9.3 Childproof brake Assa 160S	
1.9.4 Childproof ventilation fitting Assa 92	
1.9.5 Childproof ventilation fitting Assa 93	
1.10 Installing and removing handles .....	18
1.11 Handling removable glazing bars.....	19
1.12 Vents.....	20
1.12.1 Titon Pressure vent	
1.12.2 Titon select	
1.12.3 Biobe	
1.12.4 Fresh AL-dB 450	
1.12.5 Fresh 31F	
1.12.6 Omega Max and Omega Max sound	

## 2. Condensation

2.1 Internal condensation.....	24
2.2 External condensation.....	25
2.3 Condensation between casements in coupled windows.....	26

## 3. Maintenance

3.1 General information about windows maintenance.....	27
3.2 Surface treated material.....	27
3.2.1 Surface treated wood	

3.2.2 Lacquered aluminium profiles	
3.3 Cleaning the glass.....	28
3.3.1 Hard-coated energy glass	
3.3.2 Toughened glass	
3.3.3 Dirt-repellent glass	
3.3.4 Anti-condensation glass	
3.3.5 Polycarbonate glass	
3.4 Maintenance off fittings.....	31
3.4.1 Pivot hung windows	
3.4.2 Outward opening side-hung products	
3.4.3 Inward-opening, side-hung, bottom-hung products	
3.4.4 Brakes for windows and doors	
3.5 Other.....	41
3.6 Operation and maintenance instructions for blinds and pleated blinds.....	42
3.6.1 Operating instructions for blinds and pleated blinds	
3.6.2 Maintenance instructions for blinds and pleated blinds	
3.6.3 Child safety blinds and pleated blinds	
3.7 Dust filters in ventilation hatches.....	49
3.8 Mosquito nets.....	51

## 4. Warranty

## 1. User manual

Windows incorporate many different terms that you may not normally be familiar with. The images below indicate the most common terms for some of the parts contained in our window products.

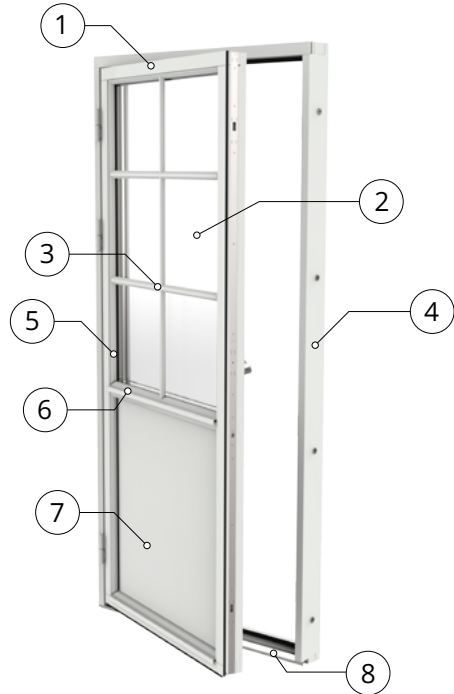

### Wooden French door

1. Door leaf
2. Double glazing
3. Glazing bar
4. Frame
5. Glazing bead
6. Glazing bridge
7. Filling
8. Threshold

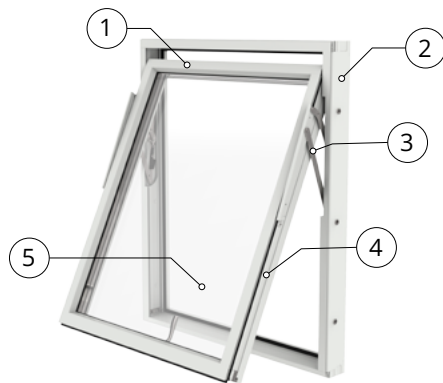

### Wooden pivot hung window with aluminium cladding

1. Aluminium cladding
2. Frame
3. Swivel fitting
4. Casement
5. Double glazing

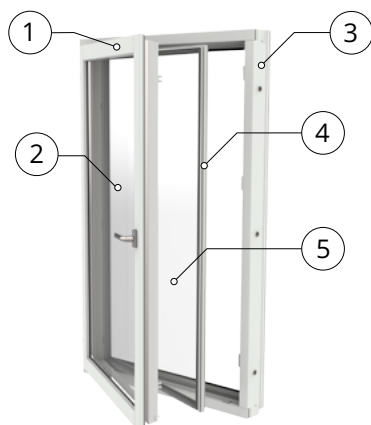

### Wooden inward opening linked window with aluminium cladding

1. Wooden inner casement
2. Double glazing
3. Frame
4. Aluminium outer casement
5. Single glazing



## 1.1 Pivot hung windows

A pivot hung window has a built-in ventilation position, a window limit stop and a cleaning position to facilitate cleaning the outside of the glass.

The ventilation position is operated by using the handle.

- Pivot hung windows have a built-in fixed ventilation position that is activated by closing the espagnolette in the external locking socket of the striking plate (a), it is controlled by the handle. By closing the handle in the outer position, a ventilation function is achieved while the casement is fixed in this position.

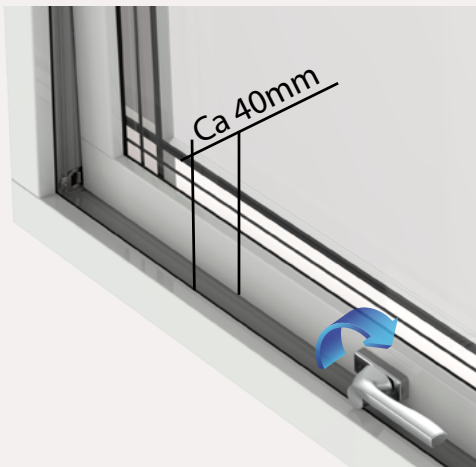

Built-in window limit stop in the swivel fitting.

- Upon opening, the window limit stop is automatically activated. The latch is located on the right side of the frame when viewed from the inside. Release the latch by pulling the black part inwards towards the room without loading the latch. The function automatically returns to normal when the window is closed.



Built-in window limit stop in the swivel fitting. Concealed fittings

- On pivot hung windows with concealed fittings, the latch is released by pushing it upward.



Cleaning position to clean the outside of the glass.

- Turn the casement around until the latch is activated. In order for this function to work, it is necessary that the exterior jamb is not too far down on the top of the window, which prevents the casement from reaching the position where the latch is activated.

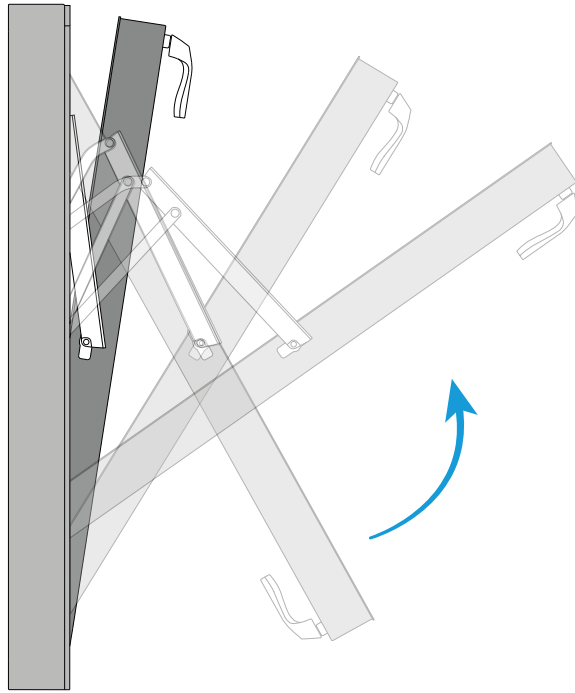

- Release the latch after cleaning by pulling the black part inwards towards the room without loading the latch. Turn the casement around and close the window.



## 1.2 Window products with Tilt-Turn fittings

A window with a Tilt-Turn function can be opened as a side-hung window as well as a bottom-hung window for ventilation.

1

Handle straight down, the window is closed.



2

Handle in the horizontal position, the window can now be opened at the top for ventilation.



3

The handle is rotated straight up to open the casement in the side-hung position. Note that the casement must be pressed against the frame when the handle is turned. To close the window, push the casement against the frame, turn the handle downwards to the vertical position.



### 1.2.1 Malfunction catch

#### Resetting the Tilt-Turn casement

If for any reason, the upper part of the fitting is out of position, the fitting must be reset as follows:

1

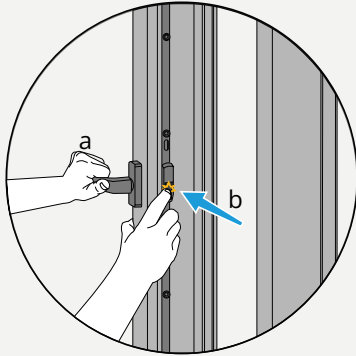

Ensure that the handle is in the horizontal position. If the handle (a) is in any other position, the malfunction catch must be (b) pressed in while turning the handle to the horizontal position.

2

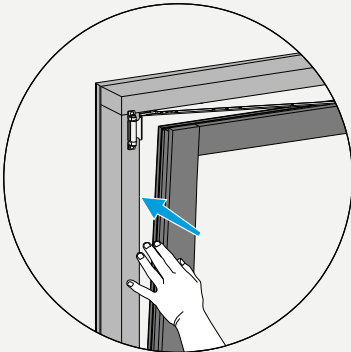

Press the hinge side of the casement against the frame while turning the handle straight up to the side-hung position with the malfunction catch pressed in. This step may require more than one person.

Figures 2 and 3

3

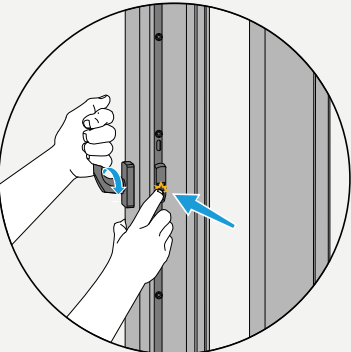

4

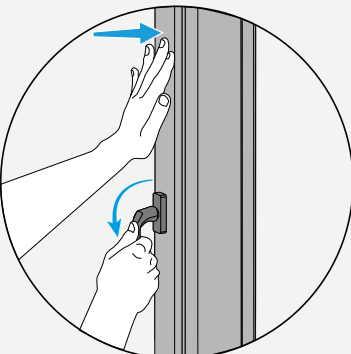

Close the casement and turn the handle downwards to the closed position. Check that the opening functions work according to section 1.2.

Figure 4

### 1.3 Switching function inward 2+1 casements

Coupled inward-opening casements and door leaves can be divided, allowing the glass to be cleaned.

When the window is open in the side-hung or bottom-hung position, the casements can be divided with one hand.

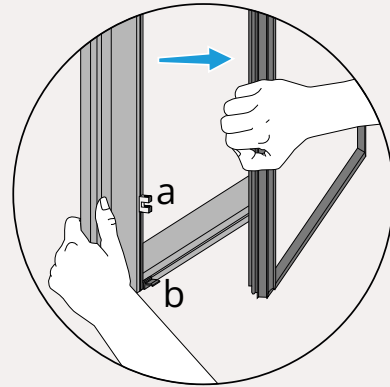

The casements are connected by snapping them together with light pressure, noting that the outer casement should rest on the plate (b). Make sure that all coupling fittings (a) are activated before the casement is closed.

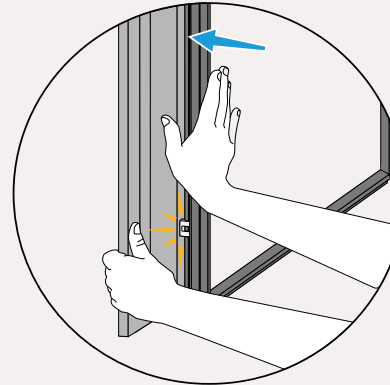

## 1.4 Switching function outward-opening 2+1 French door

Coupled door leaves can be divided, allowing the glass to be cleaned.

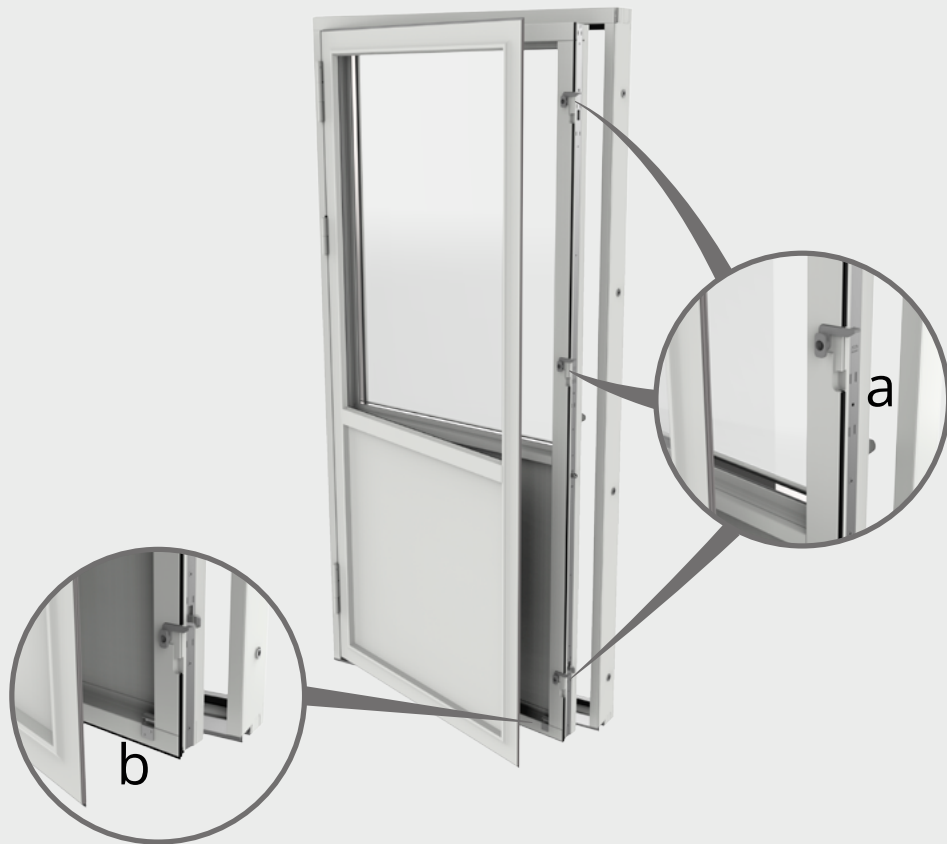

When the French door is open, the door leaves can be divided by turning the three coupling fittings (a) upwards as shown in the figure. Avoid closing the inner door leaf when the fittings are open.

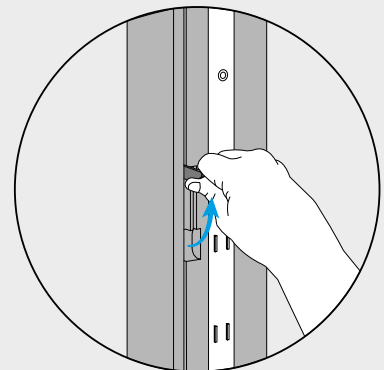

The door leaves are connected by pressing them together and turn back the coupling fittings (a) to their original positions. Note that the outer casement should rest on the plate (b) which is located on the lower edge of the inner casement.

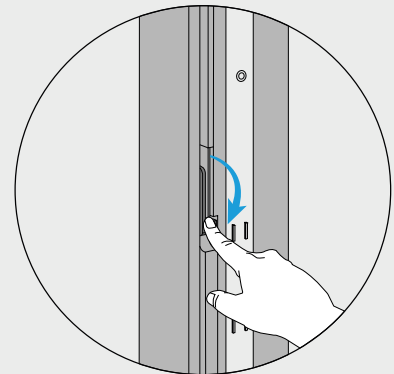
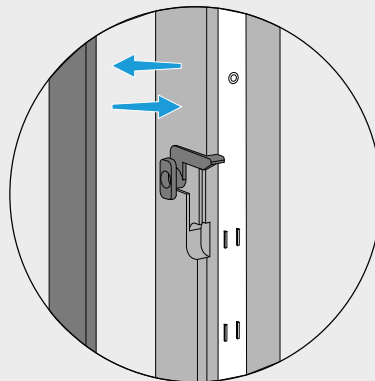

## 1.5 Bottom hung windows

Inward-opening bottom-hung windows have a scissor fitting with a built-in ventilation position, the fitting can also be opened in the cleaning position to enable the outside of the glass to be cleaned.

When the window is opened, the casement is in the ventilation position, to reach the cleaning position the latch is released (a) in the scissor fitting without the latch being loaded, whereby the casement can be opened to the cleaning position with a maximum opening of approx. 60° - 90°. Keep in mind that when the latch (a) is released, the casement should be held by hand to prevent it from falling freely. For larger window sizes, the latch is on both sides of the casement. See section 1.3 for dividing coupled casements during cleaning.

The latches are automatically reactivated when closed.

Ventilation position

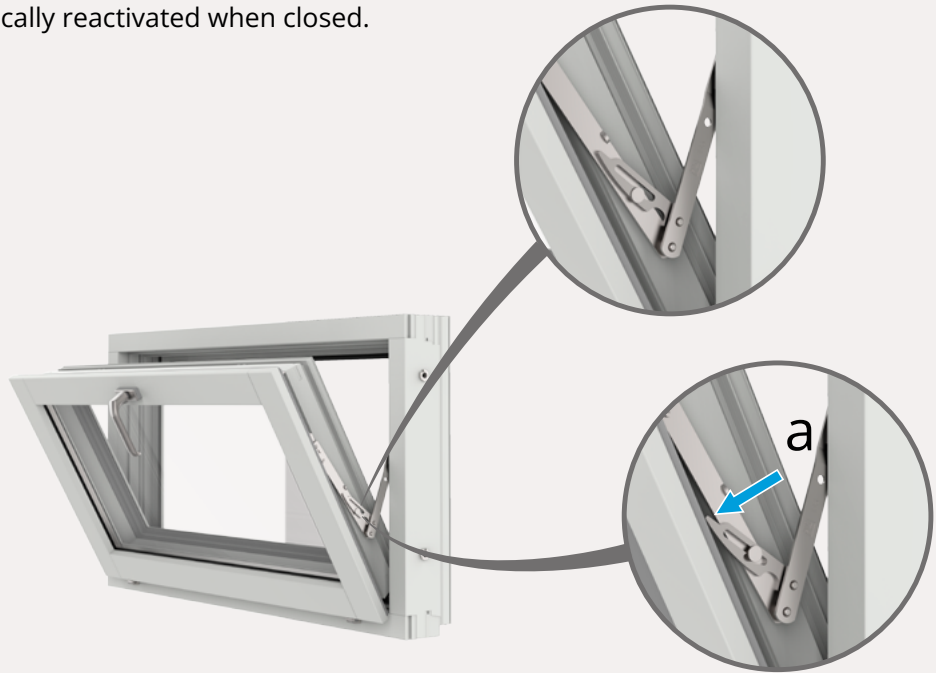

Cleaning position

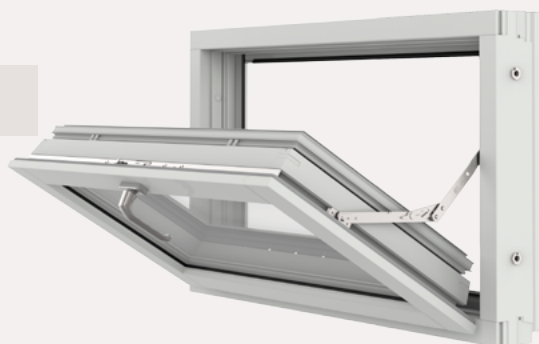

## 1.6 Handling of the passive part on double doors or windows with mullions

Double doors or windows with mullions consist of an active and a passive part. The active part must be opened before the passive part. The active part always opens with a handle, the passive part can be equipped with a handle or with flush-bolts as described below.

### 1.6.1 Outward opening double doors and windows with flush-bolts

Flush-bolts are placed on the upper and lower edge of the passive part on the lock side.

- When opening the passive part, the active part must be opened sufficiently that the folding operating arms on the flush-bolts are accessible.
- Fold out the operating arm and pull the control towards the centre of the casement and fold in the operating arm into the open position.
- When closing, the passive part is pushed against the frame to ensure that the operating arms can be returned to their original positions.

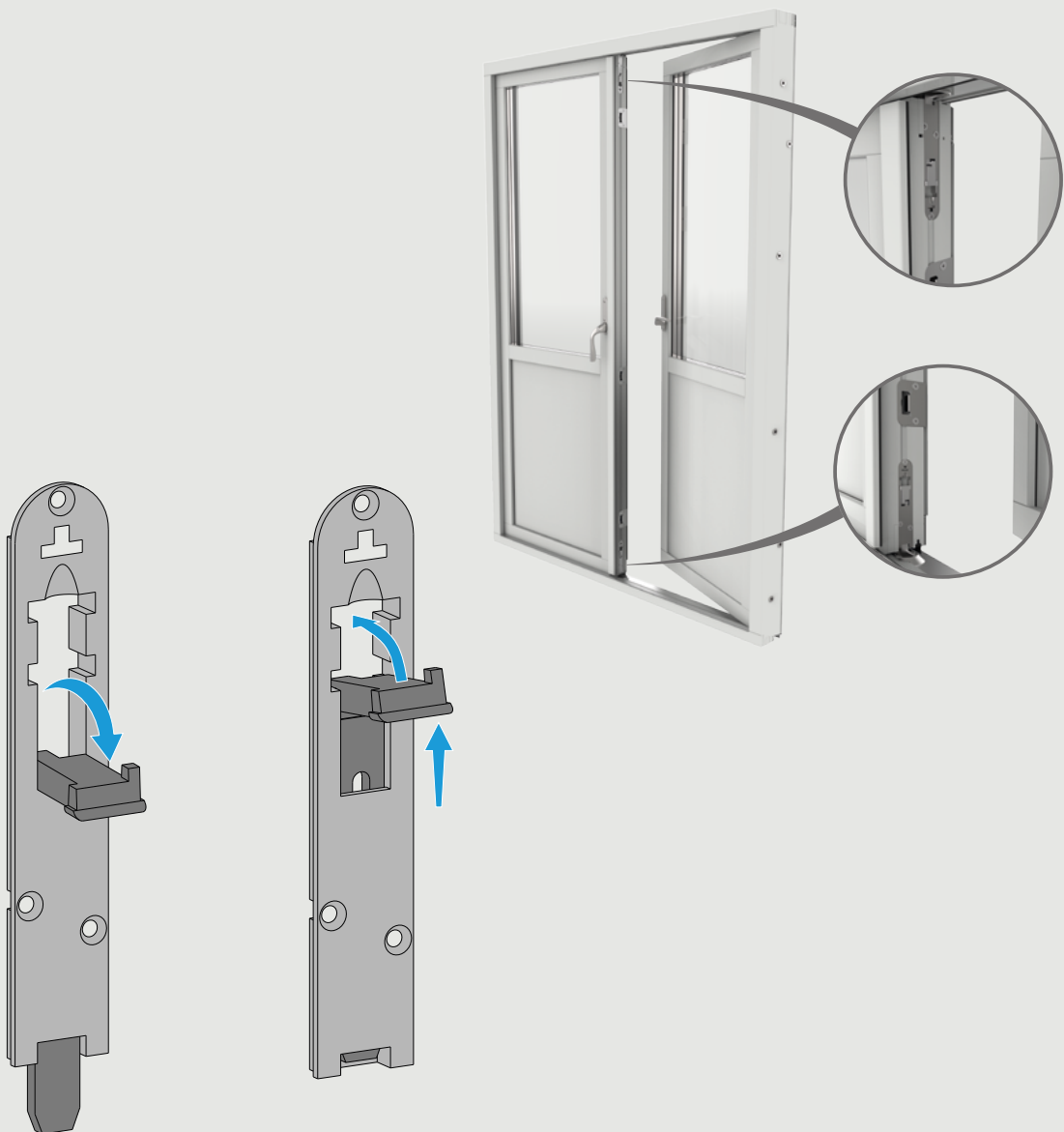

## 1.6.2 Inward-opening

Inward-opening double doors and windows with mullions.

- Open the active part so that the hidden operating arm of the passive part becomes accessible.
- Open the passive part by turning the operating arm inwards.
- When closing, the passive part is pressed against the frame to ensure that the operating arm can return to its original position.



## 1.7 Internally Visible Espagnolette

The internally visible espagnolette on side-hung double-sash windows with meeting sashes is operated as follows:



### Opening

Lift the knob over the locking bracket and turn it so that the espagnolette moves freely from the latches in the upper and lower frame sections.

### Closing

Turn the knob so that the espagnolette moves freely from the latches in the upper and lower frame sections, close the sash, then turn the knob in the opposite direction and lower the locking bracket.

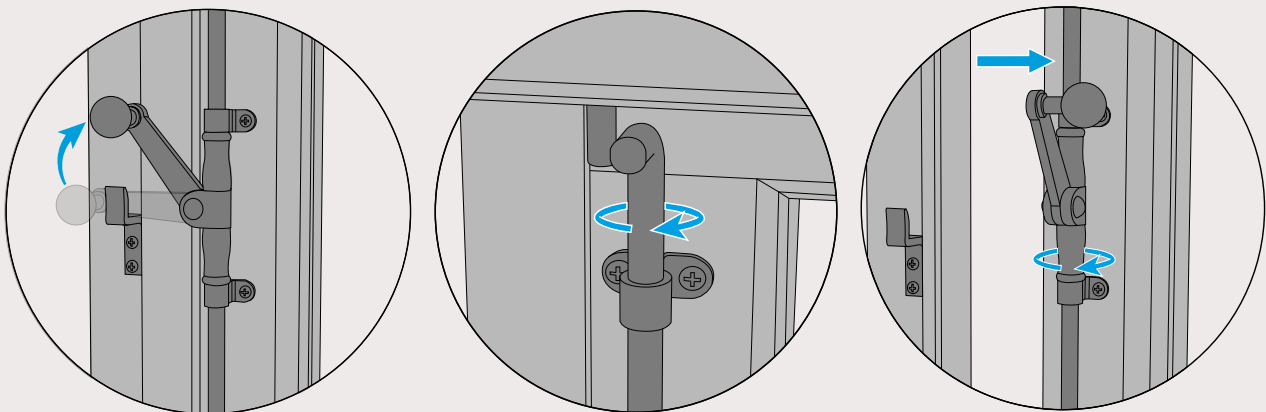

## 1.8 Brake

If the side-hung window or French door is equipped with a brake, it is located in the sash upper piece and connected to the frame upper piece.

- With the handle in the closed position, the sash is held by friction in the desired position.
- When the handle is in the open position, the brake is disengaged.

Keep in mind that if the product is open in strong winds, the brake may be overloaded and lose its function thus damaging the product.

## 1.9 Child safety fittings

For the handling of different types of child-resistant fittings, see below.

### 1.9.1 Handle Lock KISI2

See the instructions below to release the free-movement clamp.

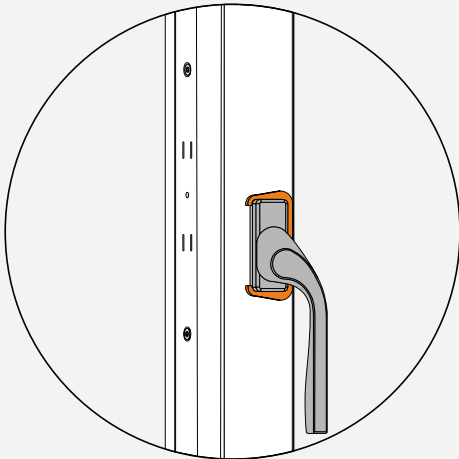

The handle lock KISI2 may sometimes be delivered with an orange free-movement clamp, which must be removed before the lock function is activated.

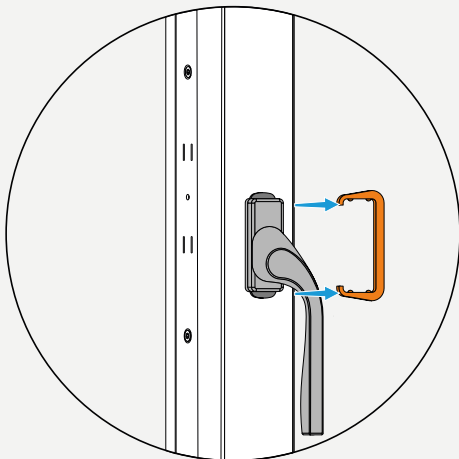

See instructions below to release the blocking latch.

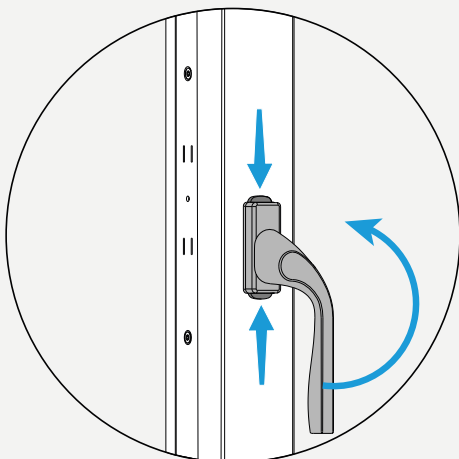

1. Release the latch by pushing in the upper and lower latches on the fittings according to the figure, turn the handle while the latches are pushed in.
2. The latch is automatically reactivated when the handle is closed.
3. Note that if the latch is on a window with a Tilt-Turn function that is opened in the side-hung position, the latch will lock the handle. To close, follow the instructions in point 1.

### 1.9.2 Restrictor Assa 184

See the instructions below to release and reconnect the restrictor.

The restrictor can be released by pressing in the spring-loaded lock tongue on the ratchet washer while unhooking the coupling.

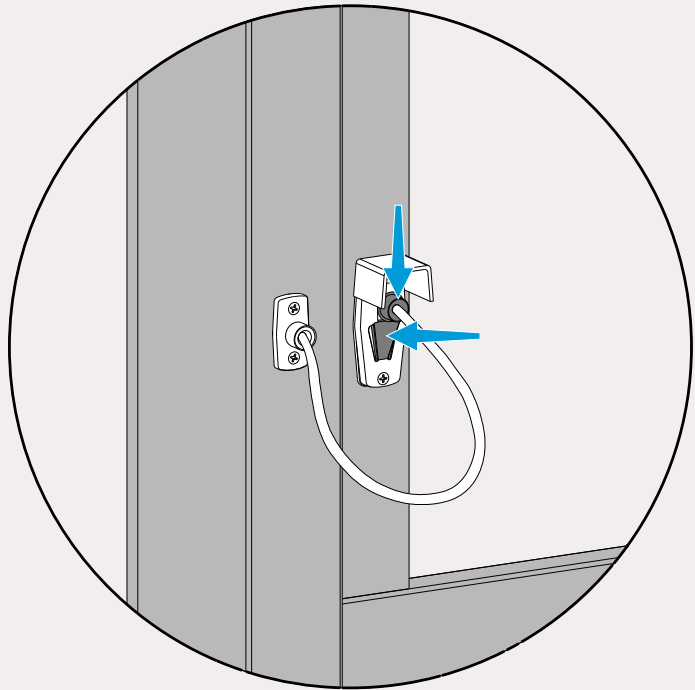

Re-engage the restrictor by pushing the coupling in towards the fitting and sliding upwards.

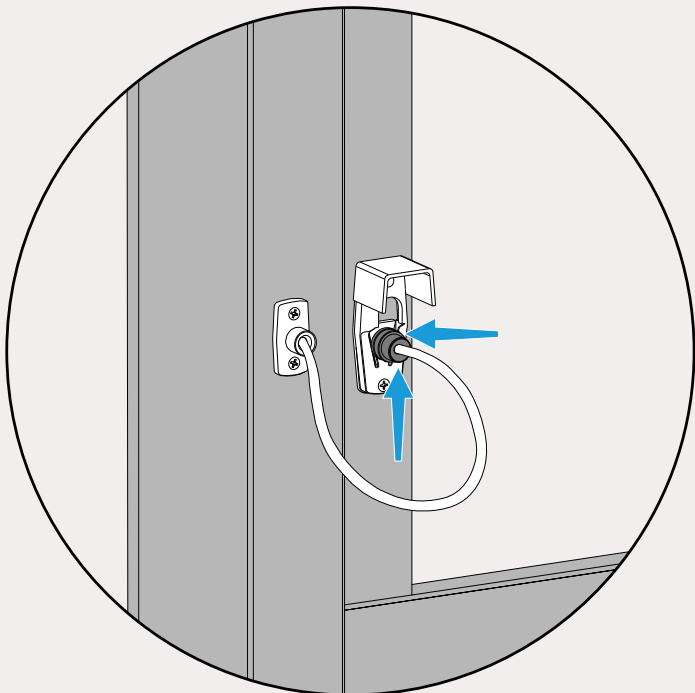

### 1.9.3 Childproof brake 160S

The Assa 160S brake has a childproof ventilation lock that is activated on delivery. This lock can also be disengaged, giving the same function as a brake without a lock.

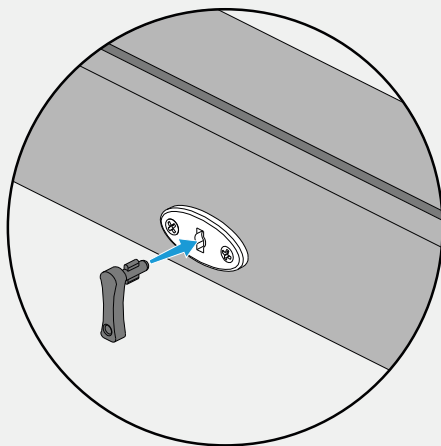

- Brake with childproof ventilation lock activated

To open the casement past the ventilation lock, the supplied key must be put in place and turned. To reactivate the function of the ventilation lock, the key must be turned back to its original position, this can be done both when the casement is open or closed. Child safety is only achieved when the key is removed.

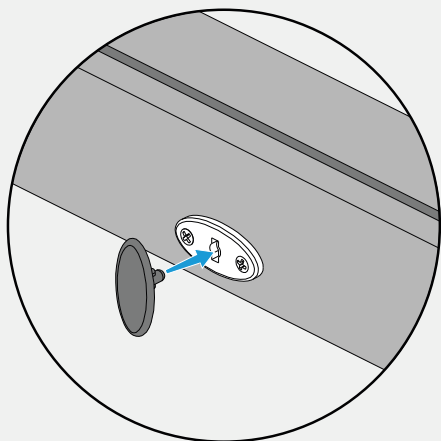

- Disengaging the childproof ventilation lock

The childproof ventilation lock can be permanently disengaged by using the supplied plastic washer. Push the washer in, turn it a quarter of a turn and the ventilation lock will be disengaged.

### 1.9.4 Childproof ventilation fitting Assa 92

Fittings for childproof ventilation on inward-opening windows are located between the lower edge of the casement and the inside of the bottom frame rail.

The fitting has a fixed ventilation position, which is automatically activated when the window is opened to the end position of the fitting.



To close the window from the activated ventilation position, the arm should be pushed to the side whereby the casement can be moved towards closure.

For openings larger than the ventilation position, the fitting can be disengaged by pushing the arm to the side through the designated opening (a). The function automatically returns to normal when the window is closed.

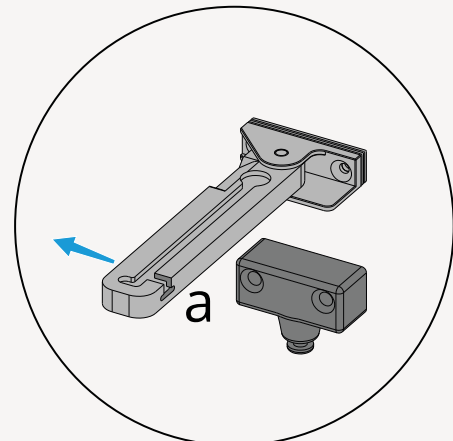
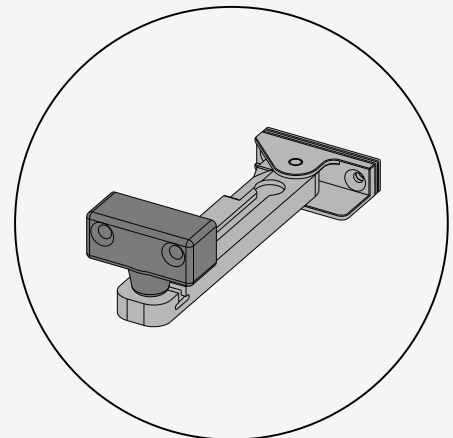

### 1.9.5 Childproof ventilation fitting Assa 93

The fitting for childproof ventilation of outward-opening side-hung windows is located between the inside of the base on the casement and the bottom frame rail.

The fitting has a fixed ventilation position that is automatically activated when the window is opened to the end position of the fitting

To close the window from the activated ventilation position, the arm should be pushed to the side whereby the casement can be moved towards closure.

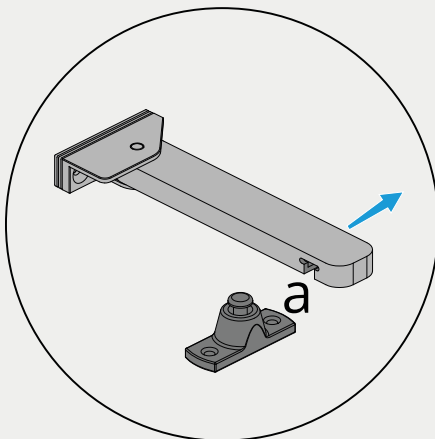
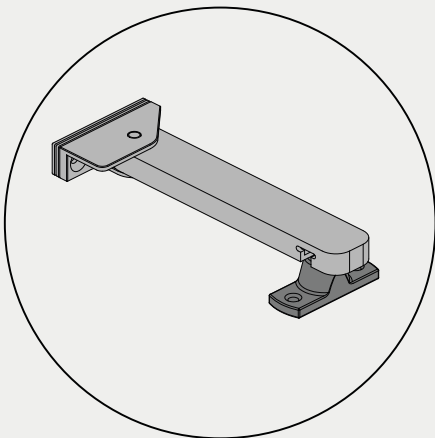

For openings larger than the ventilation position, the fitting can be disengaged by pushing the arm to the side through the designated opening (a). The function automatically returns to normal when the window is closed.

## 1.10 Installing and removing handles

This section describes how to remove and reinstall a standard handle, for example when lubricating an espagnolette.

### To remove the handle

- Open the window.
- Rotate the cover (a) by lifting lightly at the edge and turning so that the screws (b) are visible.
- Loosen and remove the screws and pull out the handle.

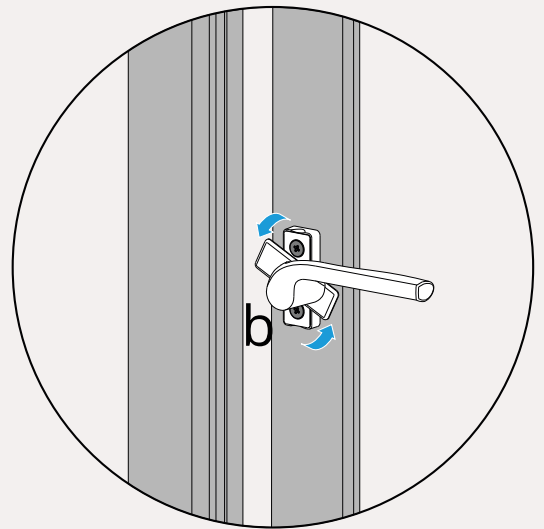
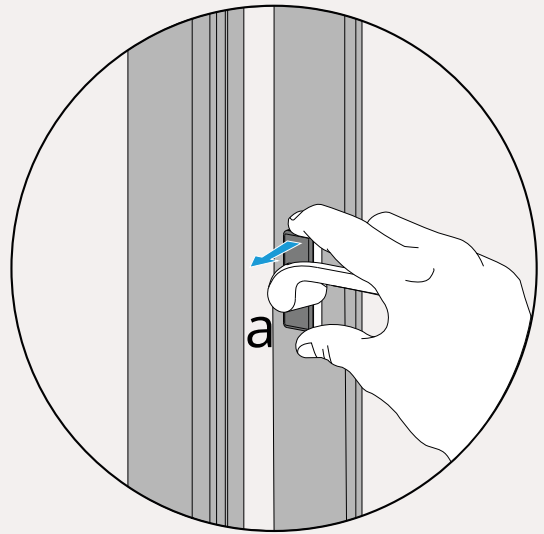

### To reassemble the handle

- Insert the handles pin into the espagnolette and fit to the handle hole.
- Reinstall the screws.
- Turn back the cover and close the casement.

Note that when reassembling handles on pivot hung windows, it may be possible that the espagnolette needs to be pushed up so that the pin on the handle can be pushed into the hole.

## 1.11 Handling removable glazing bars

Surface-mounted decorative glazing bars can be easily removed and reinstalled to facilitate cleaning the outside of the glass.

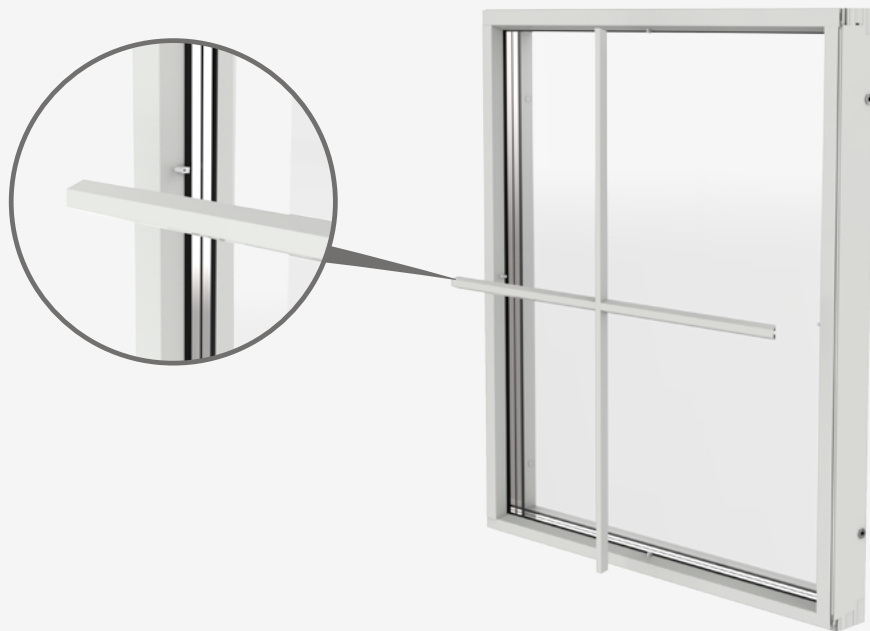

- Removing the glazing bars

Remove the glazing bar from its fastening clips by grasping the ends of the glazing bar.

Note that on wooden windows, the lower end of the vertical glazing bar should not be removed but the glazing bar should be lifted off.

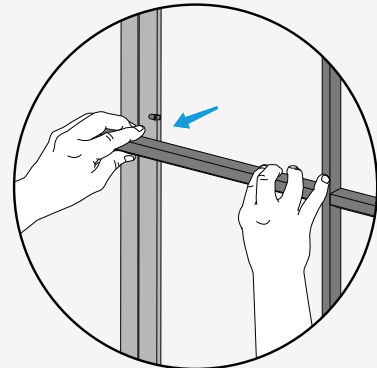

- Reinstall the glazing bar

Snap the glazing bar back onto its fastening clips using light pressure at the ends of the glazing bar.

Note that on wooden windows, the vertical glazing bar's lower end is lifted into place before the remaining fastenings are snapped back on.

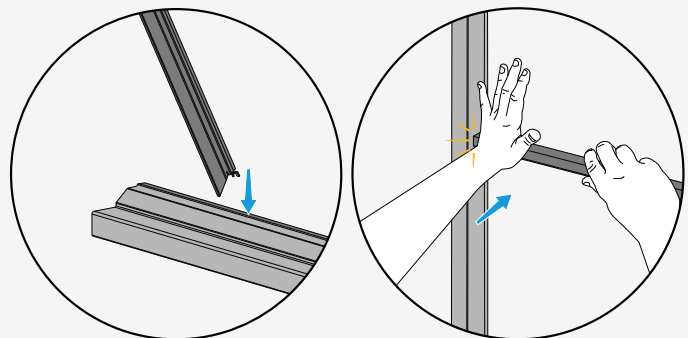

## 1.12 Vents

Vents should be cleaned periodically to prevent reduced airflow. This section describes how the most common vents are operated and maintained.

### 1.12.1 Titon Pressure vent

The vent is opened and closed by lightly pressing the vent cover. To clean the vent intake and any insect or noise filter, the inner part of the vent must be removed. The vent is mounted via spring steel to the upper and lower ends of the vent. Release the vent by easing the spring steel with a screwdriver as shown, one spring at a time and then the vent can be released.

Insect filters can be cleaned using a mild soap solution, the vent intake and any sound filters can be vacuumed or cleaned using a small brush.

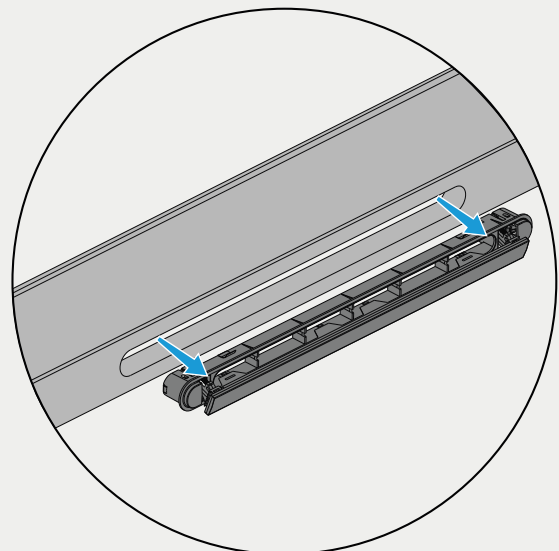
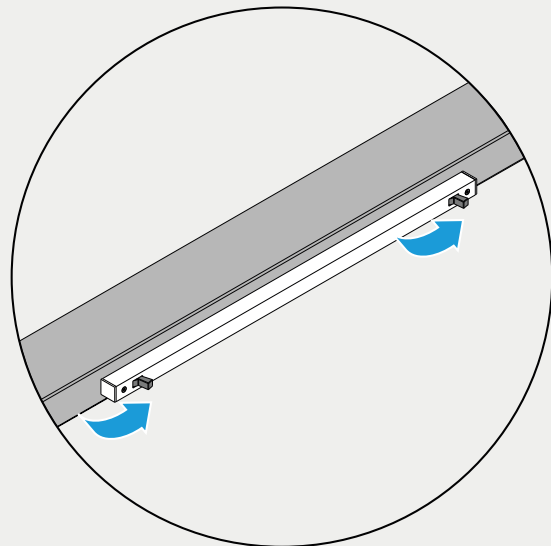
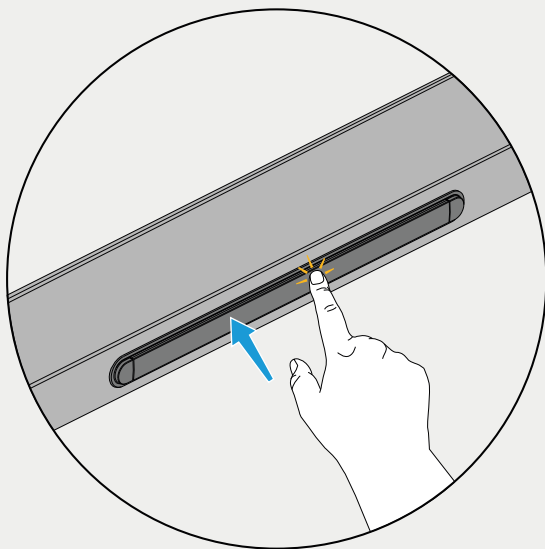

### 1.12.2 Titon Select

The vent is opened and closed by pulling the control to the side. To clean the vent intake and any insect or noise filter, the inner part of the vent must be removed. Remove the cover as illustrated and loosen the screws to release the vent. Take out any insect or noise filters. Insect filters can be cleaned using a mild soap solution, the vent intake and any sound filters can be vacuumed or cleaned using a small brush.

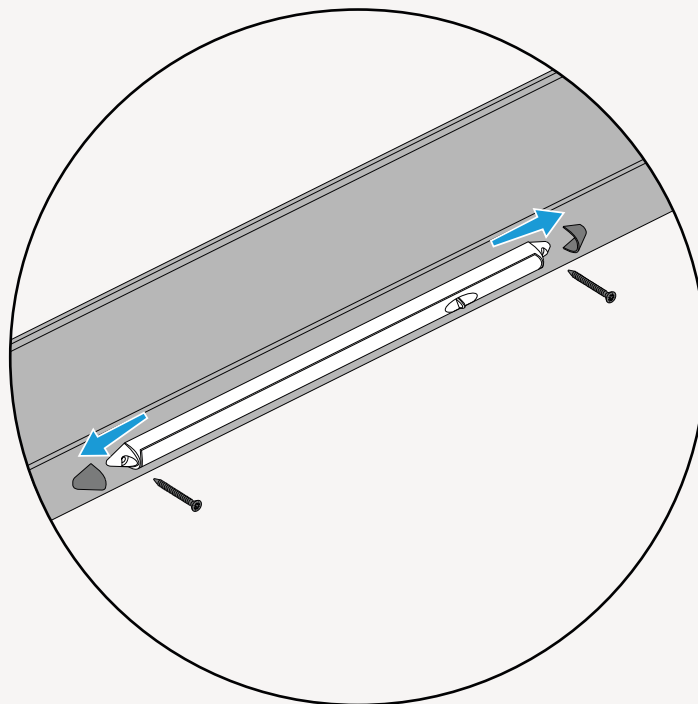
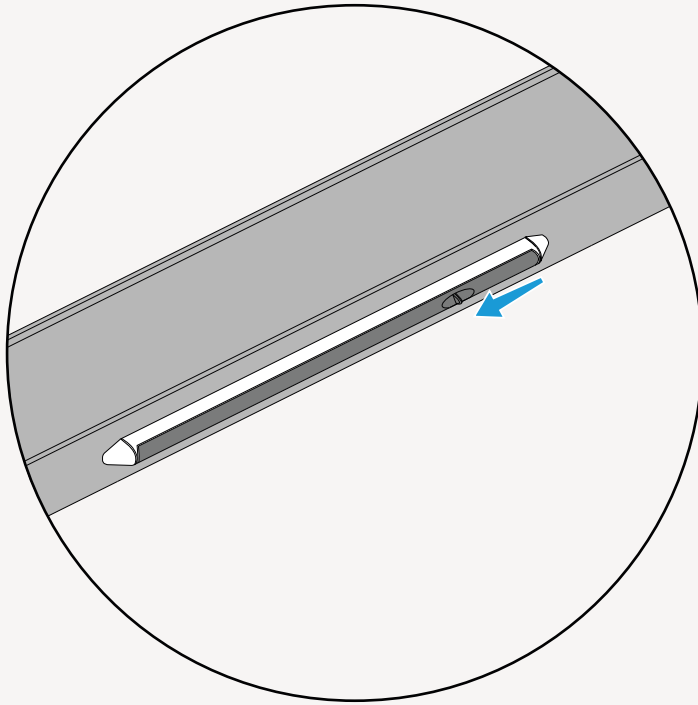

### 1.12.3 Biobe

This vent can be set in the open or closed position, but also has an intermediate position that limits the air flow. When the controls are pushed to the sides, the vent opens, and when the controls are pushed back, the vent closes. Adjust only one control to reach the intermediate position, which limits but does not close the airflow.

To clean the vent intake and any insect or noise filter, the inner part of the vent must be removed. Loosen the screws to release the vent. Insect filters can be cleaned using a mild soap solution, the vent intake and any sound filters can be vacuumed or cleaned using a small brush.

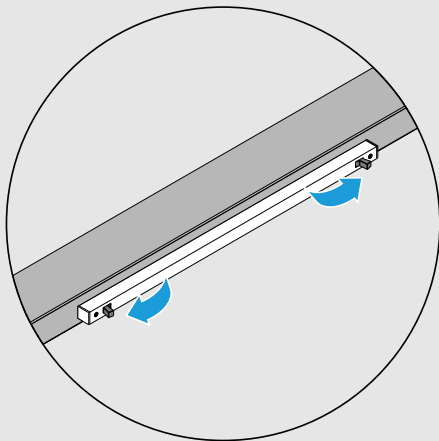

Open position

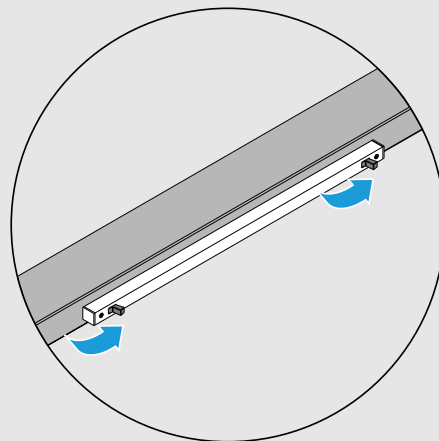

Intermediate position

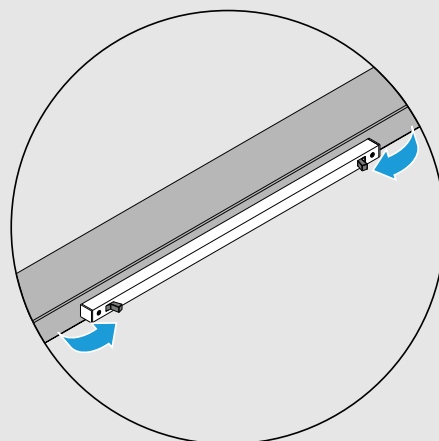

Closed position

#### 1.12.4 Fresh AL-dB 450

On this soundproofing vent, the airflow can be adjusted seamlessly by sliding the control to the side. When the control is in the outermost position, the vent is fully open, which is also marked on the control.

To ensure good air quality and a maintained flow, filters should be cleaned using a mild soap solution. The filter is located at the front, which is easy to disassemble. The vent is easy to disassemble for cleaning with, for example, a vacuum cleaner or a small brush. When disassembling, the screws for the fastening clips are loosened via the holes in the damper.

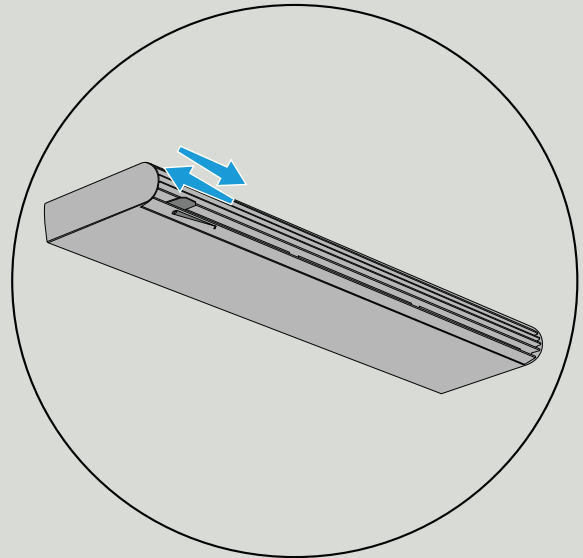

#### 1.12.5 Fresh 31F

The vent's airflow is regulated seamlessly by pulling the control sideways and when the control is in the outermost position the vent is closed, which is also marked on the control.

To clean the vent intake and any insect filter, the inner part of the vent is removed by loosening the screws on the inside of the vent. Insect filters can be cleaned using a mild soap solution and the vent intake can be vacuumed or cleaned using a small brush.

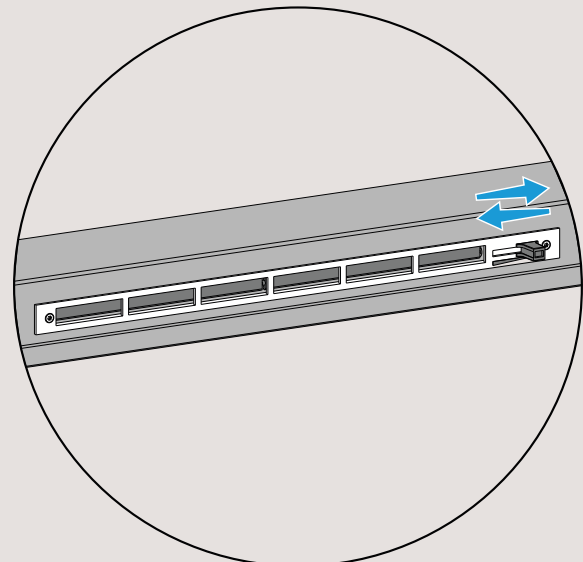

#### 1.12.6 Omega Max and Omega Max sound

This vent regulates the airflow by sliding the vent sideways. The vent is seamlessly adjustable but cannot be fully closed so as to ensure good ventilation.

To clean the vent intake and any insect or noise filter, loosen the grille of the vent by hand, whereby the screws can be loosened and the inner part can be removed. Insect filters can be cleaned using a mild soap solution, the vent intake and any sound filters can be vacuumed or cleaned using a small brush.

Note that when reassembling, the screws should not be over-tightened to ensure proper functioning of the vent.

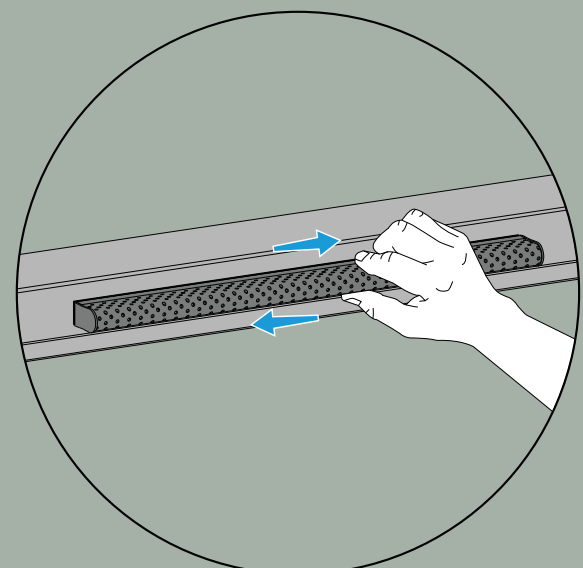

## 2. Condensation

Condensation on windows can occur on the inside of the glass, between the panes of glass in coupled casements or on the outside of the glass. There are several reasons for the occurrence of condensation, the main reason being high humidity that precipitates on a cold glass surface.

Below we describe in more detail the phenomenon of condensation and some points to consider.

If condensation occurs between the panes of insulated glass, this indicates that the glass is leaking and should be claimed within the warranty period, other types of condensation are not valid for claims.

More information regarding condensation can be found in the MTK publication titled, Condensation, which is available at [www.glascentrum-mtk.se](http://www.glascentrum-mtk.se)

### 2.1 Internal condensation

Condensation on the inside of the window occurs when warm and humid room air is cooled against a cold glass surface and is deposited in the form of mist or water droplets on the glass. This type of condensation is common on older unsealed windows but can also occur on sealed energy-efficient windows if the ventilation of the building is inadequate. In a newly constructed house, there is long-term residual moisture from built-in building materials, known as building moisture, which causes condensation.

The moisture disappears over time.

Insufficient or non-functioning ventilation increases the risk of condensation.

Deep window recesses and windowsills, as well as thick curtains, can prevent heat from flowing up along the window to heat the glass surface.

Windowsills should always be installed with a gap between the window and the sill.

Windows are designed to withstand rain and moisture on the outside but not to withstand prolonged contact with moisture on the inside. If the interior condensation occurs over a long period of time the window can become damaged, any moisture that has accumulated on the internal wooden parts of the window should be wiped away to prevent damage to the window. Higher room temperatures and good ventilation reduce the risk of condensation.



## 2.2 External condensation

Under certain circumstances, well-insulated windows may be prone to condensation on the outside of the glass. This is because the window insulates so effectively that almost no heat from the building escapes to the outer glass. On a clear night, the outer glass may be colder than the outside air and if the humidity is high, condensation will precipitate on the cold glass surface.

The risk of external condensation is higher if the window is placed in an unprotected position in the building, for example, if it is placed far out on the façade, does not have screening shrubs or trees, no roof overhangs or lowered awnings, etc. In some cases, condensation occurs mainly during a short period in autumn and spring when the difference in temperature between night and day is greater. Condensation disappears when the temperature rises and is not harmful to your windows, it is just proof of the window's good insulation capacity. Well-cleaned glass surfaces generally reduce the risk of condensation forming on the glass surface.



### 2.3 Condensation between casements in coupled windows

In windows with coupled casements, under certain conditions, condensation occurs on the inside of the outer glass, i.e., between the glass panes. Generally, the phenomenon does not occur and no single cause can be identified as several factors are involved. Condensation occurs when warm air cools down as it hits the cooled glass surface. In cold weather, ice can also form.

A common cause that can impact the occurrence of condensation between casements is incorrectly adjusted ventilation where overpressure in the building is a factor that pushes out warm indoor air into the window construction. The gap between the casements is ventilated, which under normal conditions, is sufficient to prevent condensation. The top floor can be particularly sensitive as the heat rises in the house and can cause an imbalance in the pressure on the upper floor. Other factors include if the product is incorrectly installed or if the casements or door leaves need to be adjusted. Check the closing pressure and that the sealing strip is not damaged and installed correctly.

Another cause is the presence of snow or debris on windowsills that reduces air circulation between the casements.

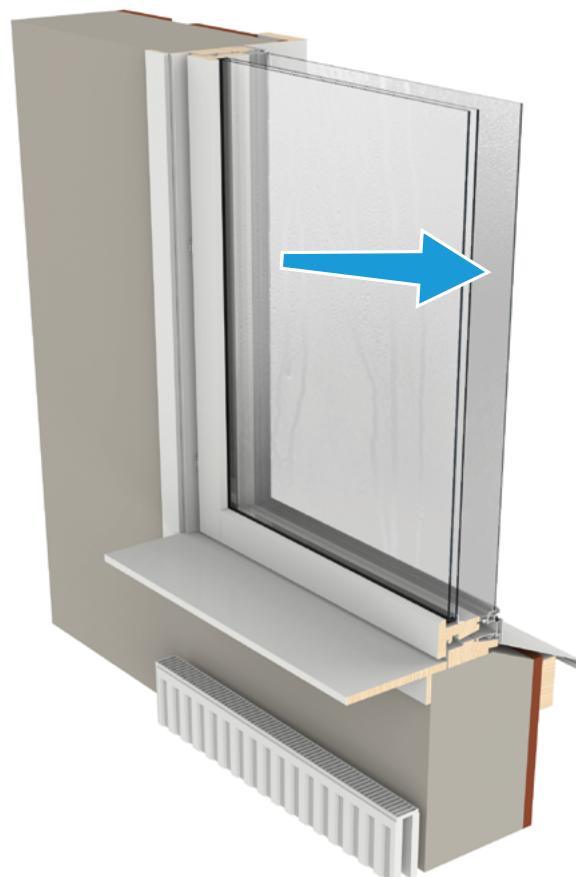

## 3. Maintenance

### 3.1 General information about window maintenance

To maintain the functionality of the window over time and to ensure the durability of the product, a certain amount of maintenance is required.

### 3.2 Surface treated materials

#### 3.2.1 Surface treated wood

The surface treatment of wood provides protection against degradation and erosion of the wood. The paint surface is exposed to a great deal of stress from precipitation, wind, UV light and pollutants which cause natural ageing of the paint surface that leads to some degradation, which is normal for the ageing process. The rate of ageing varies according to climate, weather conditions, pollution, etc. To preserve the protection of the paint surface, maintenance is required.

- Annual cleaning of the painted surfaces reduces the risk of damage, which is best done using lukewarm water and a mild detergent. And dry with a dry cloth.
- Aggressive cleaning agents with high pH-value and/or containing abrasives can damage the surface treatment and should therefore not be used
- Surface treated wood surfaces should be checked at least once a year. If damage is detected, it should be repaired as soon as possible.

Follow the instructions below to maintain surface treated wood. Please note, if masking tape is used, ensure that it is suitable for the purpose and does not damage the underlying surface.

#### Painted surfaces

- Clean using paint cleaner or water and soap.
- Remove any loose paint and sand down using fine sandpaper.
- Brush away any loose dust.
- Prime clean wooden surfaces with outdoor oil alkyd primer and follow the manufacturer's instructions.
- Seal with paint (1-2 coats) using an outdoor compatible topcoat, following the manufacturer's instructions. The internal surfaces normally only require maintenance in the form of washing with water and a suitable detergent. If painting is required, systems for interior carpentry can be used.

#### Glazed surfaces

- Damaged glazed surfaces should be cleaned in accordance with the same procedure as above.
- Treat the surfaces using oil alkyd based glaze with pigmentation adapted to the existing colour. Follow the manufacturer's instructions for glazing and finishing wood.
- The internal surfaces normally only require maintenance in the form of washing with water and a suitable detergent. If glazing is required, systems for interior carpentry can be used.

### 3.2.2 Lacquered aluminium profiles

The aluminium cladding normally requires no more maintenance than washing with water and mild detergent. To prevent the degradation of colour pigments in the lacquer, the surfaces can be waxed. Any damage, such as scratches, can be repaired by re-painting with a suitable colour for the surface. Contact your paint retailer for consultation.

### 3.3 Cleaning the glass

Clean the glass when necessary. To avoid damaging the glass during maintenance, the following points should be followed.

- The glass surface should be free of loose gravel and debris to avoid scratches when cleaning. Rinse the glass off before cleaning. This is especially important to consider if the glass surface has been subjected to soiling from renovation, construction or similar where, for example, dust from concrete can stick to the glass surface. Note that dirt from concrete must be removed immediately as it will etch into the glass and cannot be removed.
- Only use mild cleaning solutions and detergents that are designed for glass, follow the instructions on these products. Please note that cleaning glass that has any kind of surface coating should be cleaned according to the respective paragraph in this document.
- Strong or abrasive detergents should never be used to clean glass.
- Use cleaning cloths or squeegees, checking that these are clean when used to avoid scratching the glass.
- Glass should not be cleaned at high temperatures or in direct sunlight.
- Metal scrapers or razor blades should never be used on glass.

The following are recommended for spot cleaning of stubborn stains such as grease, oil, tape residue, crayons, wax materials or paint.

Recommended detergents.

- Cleaning spirits, acetone without oil, pure thinner, or agents for cleaning ceramic hobs, but not on glass with a coating as described in the next paragraph.

Cleaning method for stubborn stains.

- First clean the glass according to general cleaning instructions.
- Apply a small quantity of the detergent to a clean wet cloth or rag.
- Rub the detergent into the stain.
- Remove the dirt using a dry clean lint-free cloth or rag.
- Finish cleaning in the same way as for normal soiling, according to the general cleaning instructions.

### 3.3.1 Hard-coated energy glass

This type of glass can be placed at the outermost part of a coupled 2+1 construction. Hard-coated energy glass has a thin coating on the inside of the glass. This coating has an extremely hard surface structure that can feel slightly rough if you slide your finger on the glass. Polishing and cleaning of the coated surface should be carried out in accordance with these instructions.

Cleaning instructions for new glass that has not been previously cleaned.

- The inside of the outer glass should first be cleaned using a mixture of water and methylated spirits (three parts water and one part methylated spirits), then rinsed off with plenty of water and dried with a clean, lint-free cloth. After this, the glass should also be cleaned according to the instructions. General cleaning instructions for hard-coated glass.
- The outside of the glass should be cleaned according to the General cleaning instructions for hard-coated glass.

General cleaning instructions for hard-coated glass.

- Rinse off the glass using plenty of water to remove loose particles that could scratch the glass surface.
- Mix a few drops of detergent with water, do not use the detergent "Yes" which is slightly greasy and is not suitable for window cleaning.
- Apply plenty of the mixture to the windowpane using a well-soaked sponge or cloth to remove the dirt.
- Remove the mixture from the glass surface with a squeegee and wipe off any water residue on the casement using a cloth.
- Allow the surface to dry. The remaining layer of moisture evaporates quickly and results in a clean glass surface without streaks.

**NOTE!** Do not use a cloth to wipe the glass pane dry as this may cause "flaming".

Be careful when using the squeegee that no metal parts scratch the glass. If satisfactory results are not achieved, replace the detergent with vinegar. Mix one part vinegar with ten parts clean water.

Removing metal residue.

Avoid razor blades, steel wool or other metal objects coming into contact with the coated glass surface. Should this happen, a thin film of metal may stick to the coated surface. This can result in a colour change that can be perceived as a scratch in the glass. These marks shall be removed according to the following method.

Recommended detergents.

- Concentrated vinegar.

Cleaning method

- First clean the glass according to the General cleaning instructions for hard coated glass.
- Apply a small quantity of the detergent to a clean wet cloth or rag.
- Rub the detergent into the stain.
- Remove the dirt using a dry clean lint-free cloth or rag.
- Finish cleaning in the same way as for normal soiling according to the General cleaning instructions for hard-coated glass.

### 3.3.2 Toughened glass

Cleaning toughened glass requires special care. Toughened glass can have a surface structure consisting of small, elevated glass particles. When cleaning this surface, it is important not to use a method that "chops" these particles off the surface, thereby causing scratching. Otherwise, general instructions for cleaning glass apply.

### 3.3.3 Dirt-repellent glass

Dirt-repellent glass has a surface coating that reduces the need for cleaning. The surface is activated by UV light and a process starts which breaks down organic pollutants. When it rains, the dirt is washed off the glass surface. NOTE! Carefully protect the glass from splashes of paint, plaster, etc. during construction and maintenance.

Maintenance of dirt-repellent glass. When the window is newly installed.

- Rinse off the glass with water to remove any loose particles that may scratch the glass surface.
- If a window scraper is used, make sure that no metal parts come into contact with the glass!
- Wash the glass using a lukewarm soap solution and a soft cloth, removing any splashes of paint with a soft cloth and methylated spirits or white vinegar. If necessary, ordinary non-abrasive window cleaner can be used. Never use abrasive detergents or those containing oil or grease, as they will inevitably damage the coated surface.
- Rinse off with water and wipe dry with a clean, lint-free cloth.
- The dirt-repellent surface is activated after approx. 1 week.

Regular cleaning is not normally necessary provided that rainwater can reach the window to wash away the dirt. For longer periods of dry weather, the glass can be rinsed with a hose and allowed to dry naturally.

### 3.3.4 Anti-condensation glass

Anti-condensation glass should be maintained and cleaned in the same way as hard coated glass as described in part 3.3.1 of this document.

### 3.3.5 Polycarbonate glass

Polycarbonate glass such as Hammerglass® is coated with a hard surface layer of silicon oxide. As with ordinary glass, tools or objects that could cause scratching should not be used for cleaning.

Cleaning.

- For cleaning, we recommend ordinary dishwashing liquid and lukewarm water.
- Cleaning should only be done with soft cloths or squeegees that do not have hard particles.
- Damage such as graffiti should be removed using solvents such as isopropanol or white spirit. Acetone must not be used.

### 3.4 Maintenance of fittings

To maintain the function of an openable window or French door, the moving parts of the fittings should be maintained at regular intervals. This section describes how fittings should be maintained and at what interval.

#### 3.4.1 Pivot hung windows

##### 1. Opening function

In order to maintain the opening function of the window, the espagnolette and striking plate should be maintained 1 to 2 times a year. Use a lubricant such as lock oil or sewing machine oil without silicone.

The espagnolette can be lubricated from the underside of the casement or by removing the handle.

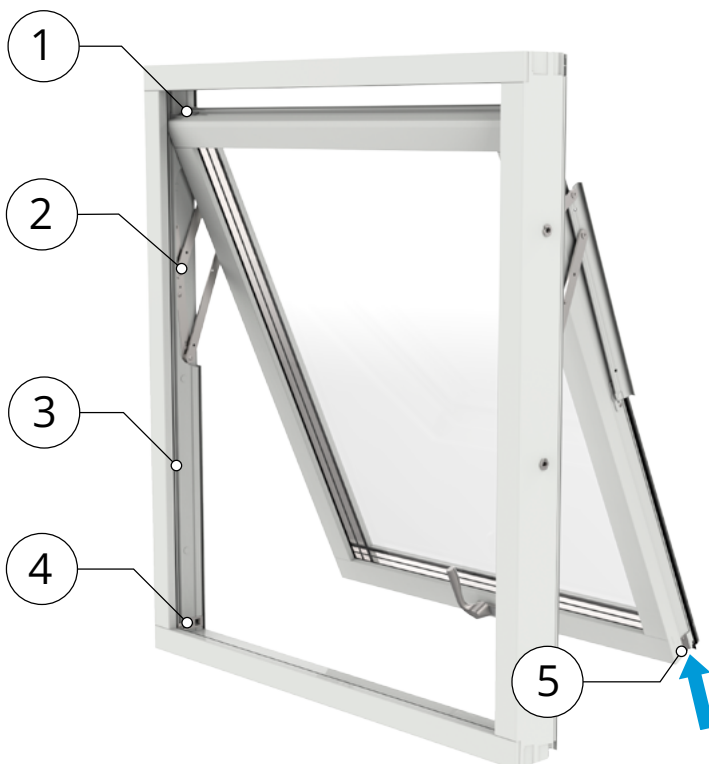

- 1. Top fittings
- 2. Swivel fitting
- 3. Slide rail
- 4. Striking plate
- 5. Espagnolette

The espagnolette can be lubricated from the underside of the casement or by removing the handle.

Lubrication from the underside of the casement.

- a) Open the window a few decimetres
  - b) The lock housing is located in the centre of the handle.
- Spray from the side of the lock housing.
- c) Turn the handle back and forth so that the oil spreads

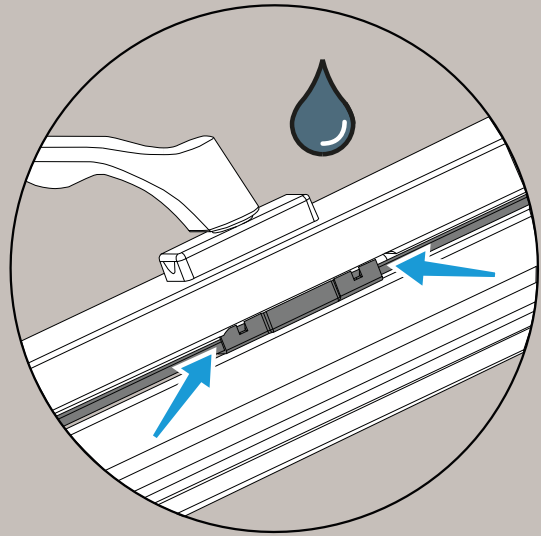

Lubrication by removing the handle.

- Remove the handles according to point 1.9 of this document.
- Spray the oil so that it flows into the lock housing.

Refit the handle according to point 1.9 of this document and turn it a few times so that it moves easily.

Wipe off any lubricant that dripped onto the bottom frame rail.

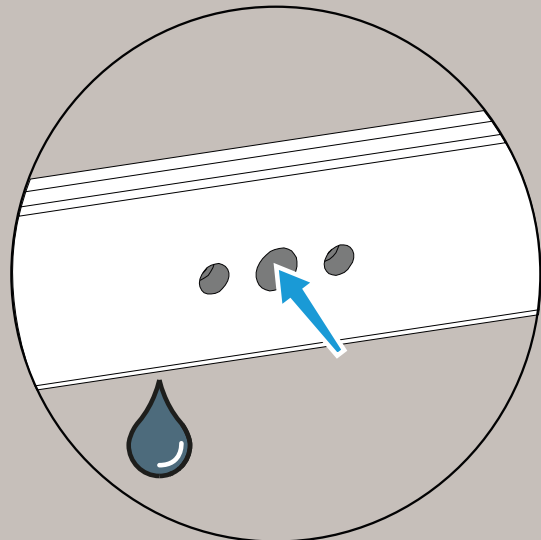

Also, clean and lubricate the striking plate so that the roller on the striking plates can be turned.

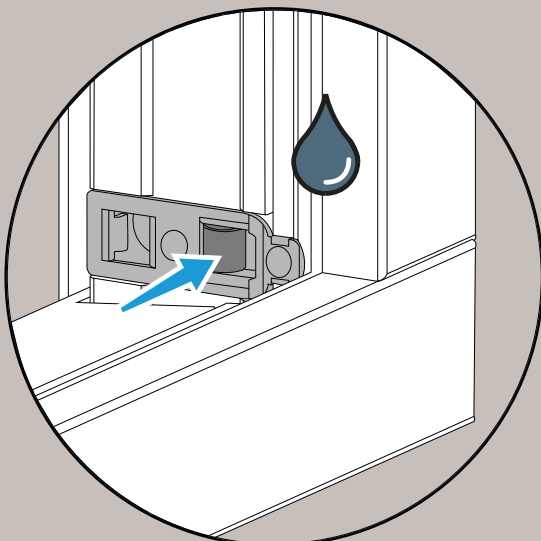

## 2. Pivot function.

To ensure the window's pivot function, the window's pivot fitting, top fitting and slide rail should be maintained 1-2 times a year.

### Pivot fittings.

Open the window and lubricate the moving parts and rivets on the fittings.

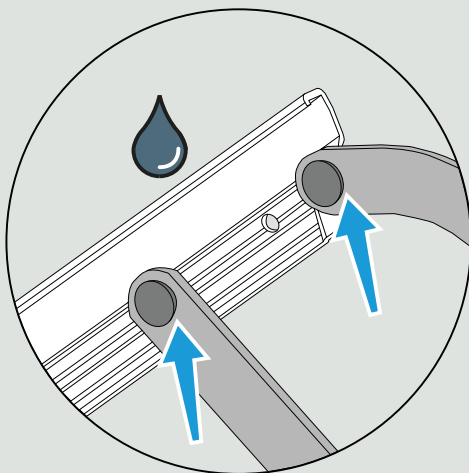
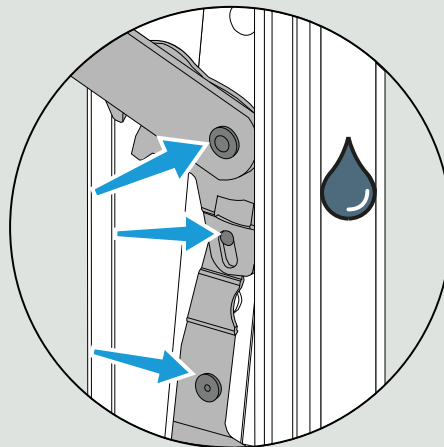
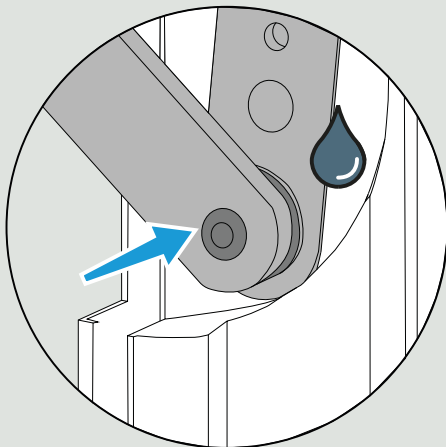

Top fittings and slide rail.

Open the window so that the rivet on the top fitting is accessible for lubrication.

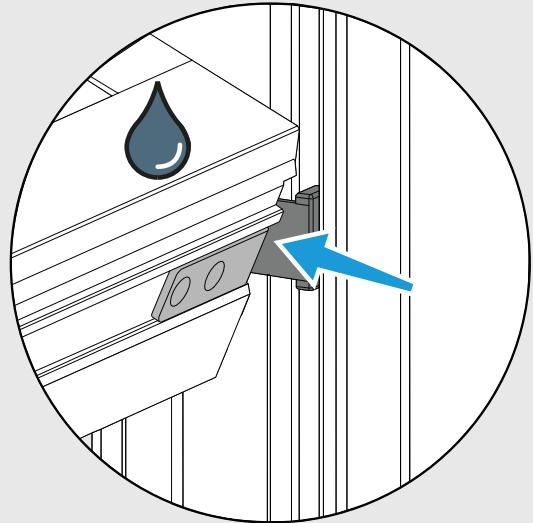

Also lubricate the slide rail with acid-proof Vaseline using a small brush and turn the window upside down a few times.

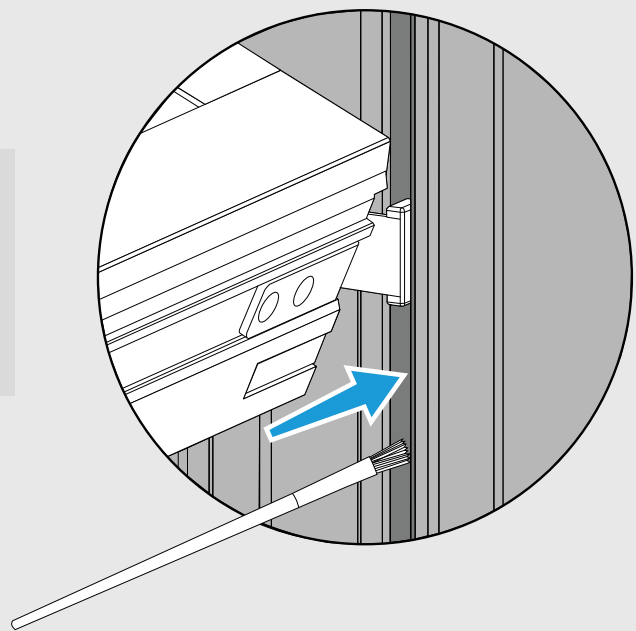

### 3.4.2 Outward opening side hung products

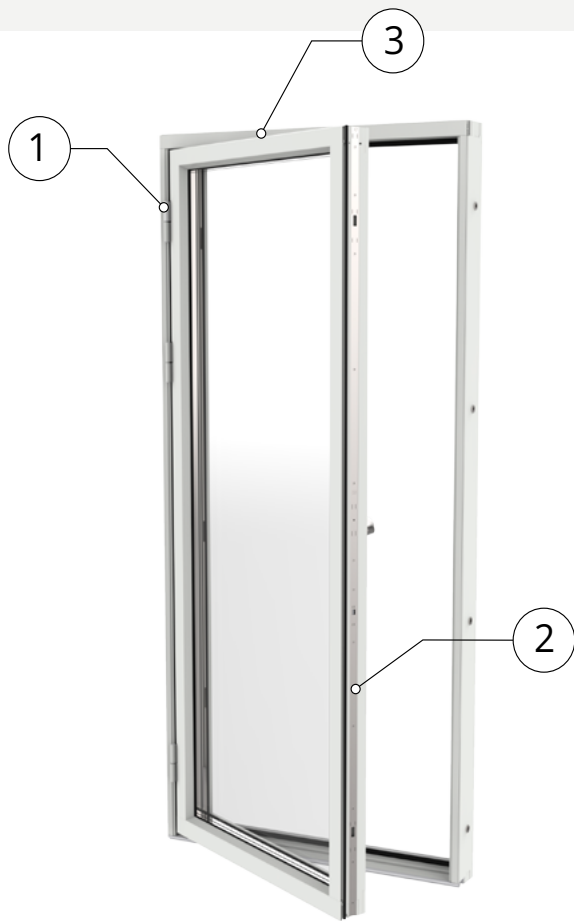

1. Hinges
2. Espagnolette
3. Brake

#### 1. Hinges

To prevent wear and noise in the hinges, they should be lubricated at least once a year with a lubricant such as lock oil or sewing machine oil without silicone.

##### Hinges with removable cover

- Apply lubricant to all hinges
- Refit the covers, open and close the product a few times.
- Note that on French doors with coupled outer casements, the outer casement must first be unhooked so that the screw pin on the upper and lower hinge can be removed.

##### Hinges without removable cover

- Apply locking spray between the upper and lower hinge parts. Open and close the casement a few times.

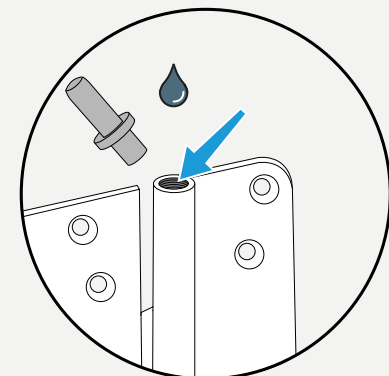
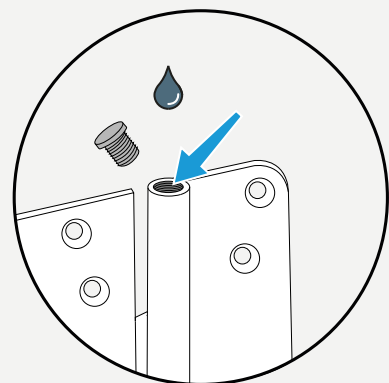

## 2. Espagnolette

Our espagnolettes and multi-point locks are lubricated and their function is checked on delivery. In order to maintain a good function and increase the life of the product, the lock housing, all pistons and the brake transmission should be lubricated with a few drops of oil 1-2 times a year. Use a lubricant such as lock oil or sewing machine oil without silicone. The number of lubrication holes/pistons varies depending on the product type.

### Espagnolette rail

Lubricate the locking cylinder, lubrication holes and the lock housing as shown. Turn the handle a few times after lubrication.

See section 3.4.4 brake maintenance.

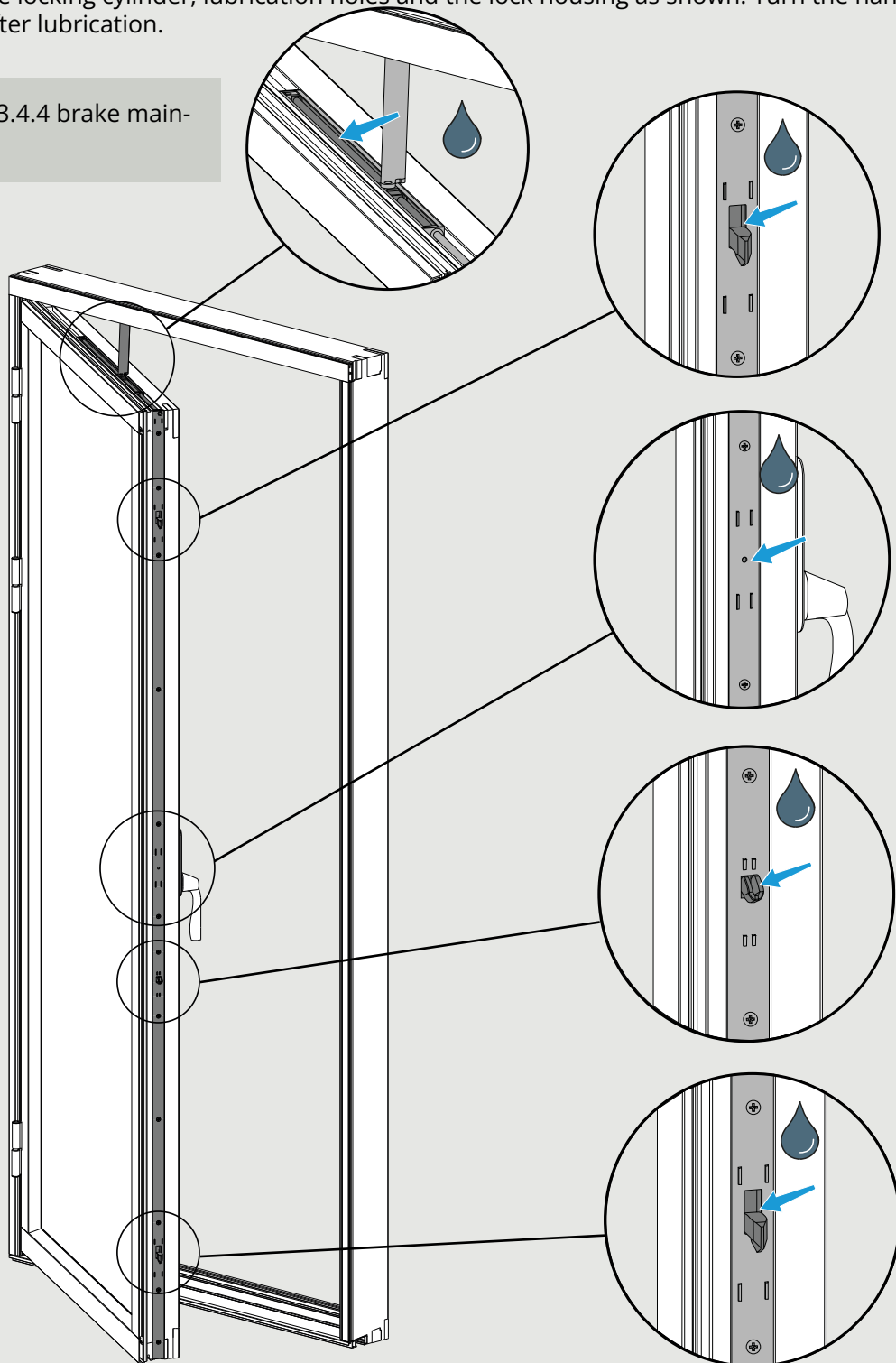

### 3.4.3 Inward-opening side-hung, bottom-hung products

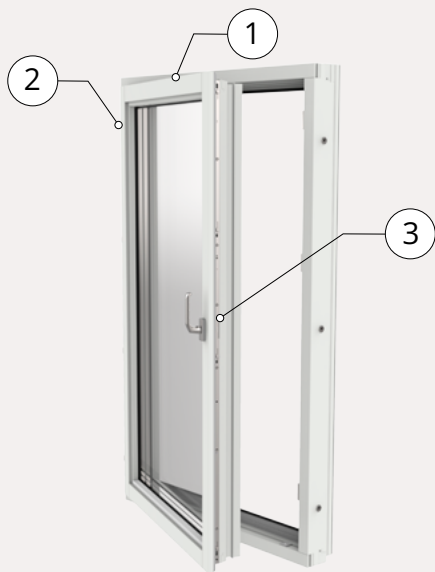

#### Side-hung windows and French doors

- 1. Brake
- 2. Bolt hinge
- 3. Espagnolette



#### Window products with Tilt-Turn

- 1. Upper hinge
- 2. Lower hinge
- 3. Scissor fitting
- 4. Espagnolette

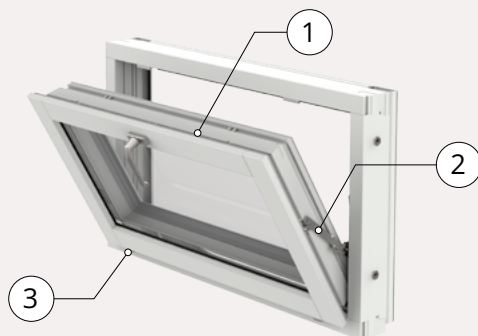

#### 1.5 Bottom hung window

- 1. Espagnolette
- 2. Scissor fitting
- 3. Bolt hinge

The fittings should be lubricated 1-2 times a year as described below.

- Clean the fittings and locking points from dirt.
- Lubricate all moving parts and locking points as shown in the diagrams.
- Use a lubricant such as lock oil or sewing machine oil without silicone.
- Check that all fittings are firmly attached and not worn. Ensure that the fixing screws are firmly tightened and that defective parts are replaced where necessary.

### Side hung.

See section 3.4.4 brake maintenance.



## Tilt-turn.

Lubricate all moving parts on the fittings.

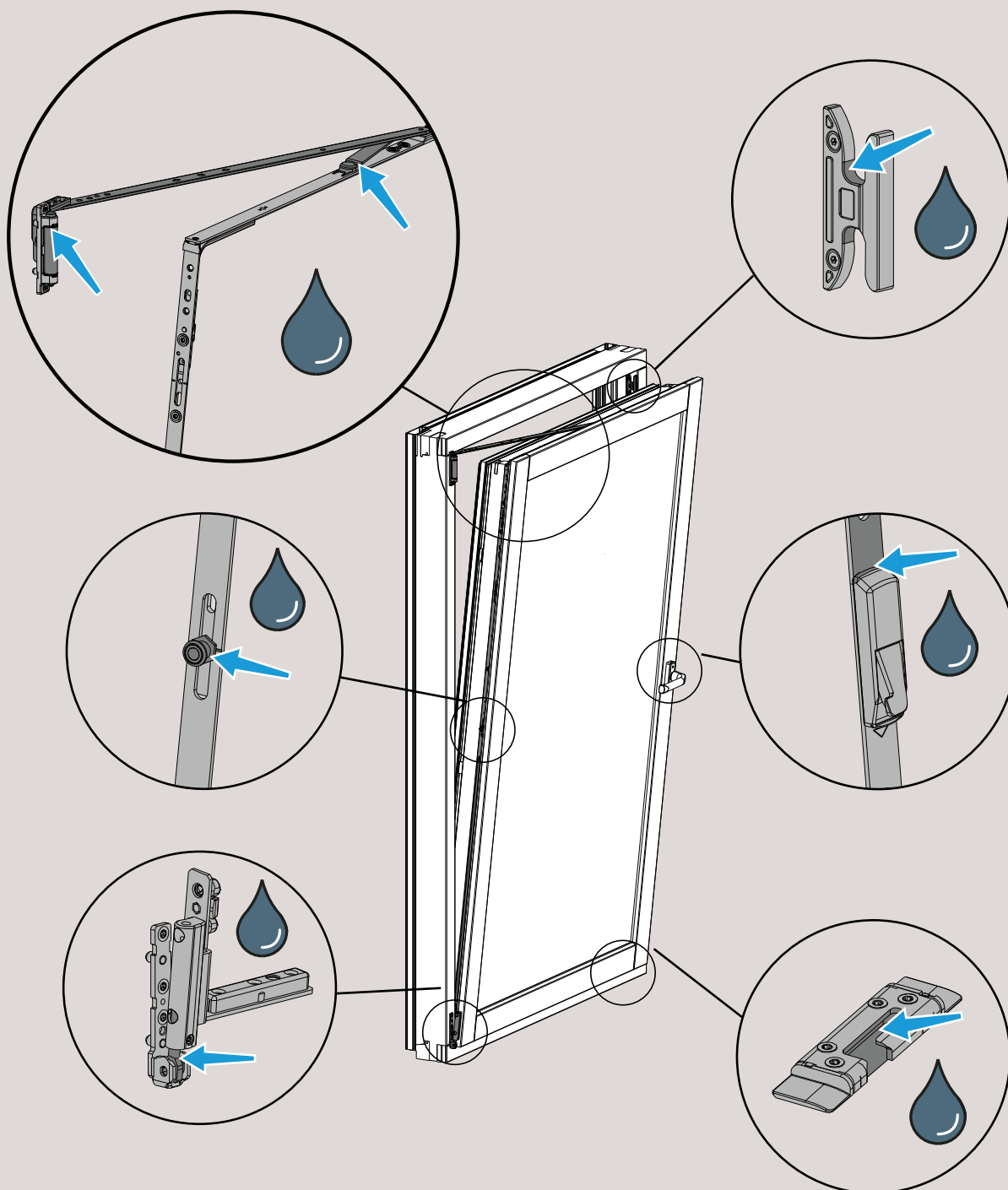



### 3.4.4 Brakes for windows and doors

Installed window brakes shall be continuously cleaned by vacuuming and wiping with a dry cloth. The window brake should not be lubricated as this may affect the friction and cause the locking function to fail. If the brake has not been cleaned continuously, it can become sluggish, in which case we recommend gently lubricating it with a little oil or Vaseline. Be careful not to over-lubricate the brake as this can affect its performance.

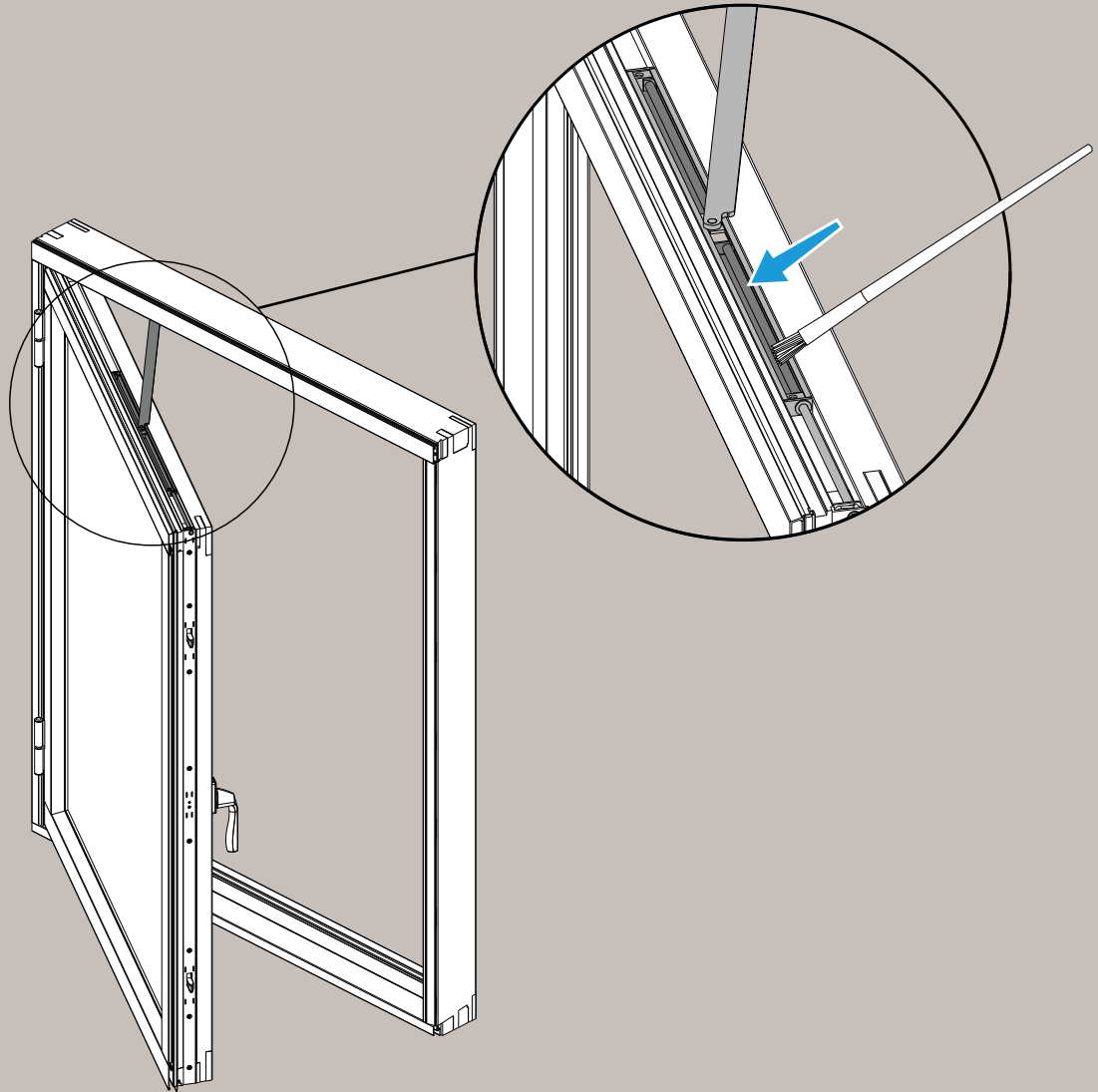

### 3.5 Other

#### Sealing strips

- To maintain the function and tightness of the window product, the sealing strips should be kept clean by using a slightly damp cloth. Damaged strips reduce the insulation capacity and should be replaced. Visit Elitefönster's accessory store for replacement strips if the strips are damaged.

#### Drainage holes for inward opening windows

- Ensure that the drainage holes in the bottom frame rails are not blocked, clean if necessary. This is done by opening the inward-opening window and wiping the lower aluminium cladding of the bottom frame.

### 3.6 Operation and maintenance instructions for blinds and pleated blinds

#### 3.6.1 Operating instructions for blinds and pleated blinds

Sunshades are available in different types and designs, the most common of which are described below.

Operation and maintenance may differ depending on the type of sunshade. When using sunshades operated by cords, care should be taken to ensure child safety.

To avoid large temperature differences in the glass, which can cause cracks in the glass, blinds or pleated blinds in dark colours should always be used either fully up or down.

#### Internal blinds

Blinds placed on the inside of the window.



The blind is operated with a cord and a wand.

When raising or lowering the blind, release the cord from the cord collector and gently pull or release the cord to the desired height. Secure the cord in the cord collector, note that no loose cords should be below 1.5 metres from the floor as per child safety requirements, see section 3.6.3 of this document.

To angle the blind, turn the wand clockwise or anti-clockwise, respectively, until the desired position is reached.

## Integral blinds

Blinds that are placed between the glass panes of a window product with divisible casements.



An integral blind has a grommet for cords and the wand to allow the cord to run unhindered when the blind is raised or lowered.

- Raise the blind

Release the cord from the cord collector and pull the blind up. In order for the blinds to run smoothly through the gap in the cord guide, they should be pulled slightly away from the window, i.e., towards the room (see figure). Secure the cord in the cord collector, note that no loose cords should be below 1.5 metres from the floor as per child safety requirements, section 3.6.3 of this document.



- Lower the blind

Release the cord from the cord collector and hold the cords inwards from the window so that the cover of the cord guide opens (see figure). Lower the blind to the desired height and lock the cords in the cord collector. Note that no loose cords should be below 1.5 metres from the floor as per child safety requirements, see section 3.6.3 of this document.

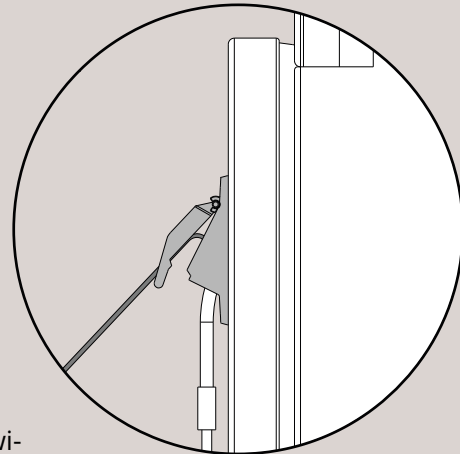

To angle the blind, turn the wand clockwise or anti-clockwise, respectively, until the desired position is reached.

## Blind Plus

A blind without a cord, placed on the inside of the window.



The blind is manoeuvred upwards or downwards by pulling both handles on the blind's lower strip.

This blind has no loose cords, which means that it meets all requirements regarding child safety.

To angle the blind, turn the wand clockwise or anti-clockwise, respectively, until the desired position is reached.



## Pleated Standard

Pleated blinds that are placed on the inside of the window.



The pleated blind is operated using a cord.

When raising or lowering the blind, release the cord from the cord collector and gently pull or release the cord to the desired height. Secure the cord in the cord collector, note that no loose cords should be below 1.5 metres from the floor as per child safety requirements, see section 3.6.3 of this document.

## Pleated Top down

A blind without a cord, placed on the inside of the window.



The pleated blind is manoeuvred up or down by pulling the handle on the top or bottom rail of the pleated blind.

This pleated blind has no loose cords, which means that it meets all requirements regarding child safety.

### 3.6.2 Maintenance instructions for blinds and pleated blinds

#### Blinds

- Turn the blind slats, vacuum gently with a brush nozzle or wipe with a slightly damp cloth.
- Be careful not to damage the slats.
- The blinds must not be closed when wet.

#### Pleated blinds

- Vacuum gently with a brush nozzle or wipe using a slightly damp cloth.
- Use a cloth that does not leave colour on the pleating.

### 3.6.3 Child safety blinds and pleated blinds

Loosely hanging cords can be a choking hazard if children can reach them. We supply sunscreens that comply with the European standard EN 13120, which means that when correctly installed and handled, they fulfil the requirements of the Swedish National Board of Housing, Building and Planning for child safety. Follow the installation instructions and ensure that loose cords are collected in the cord collector during use.

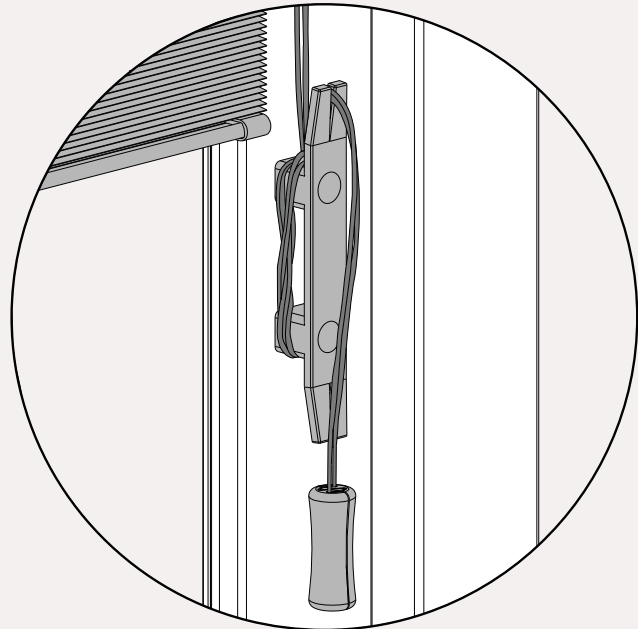

If the safety tassel has split, it is connected as follows:

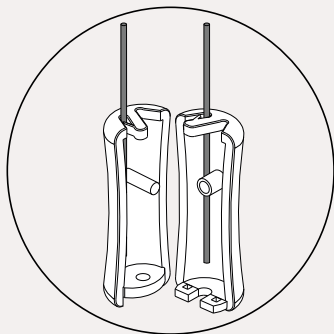

1. The two halves of the safety tassel remain on their respective cord.

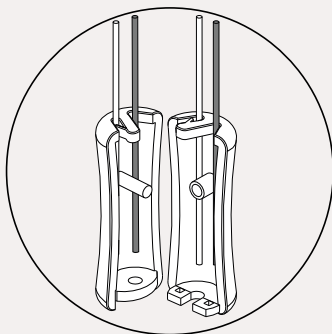

2. If there are more than two cords, they are placed in the groove of one of the halves, 1 cord per groove.

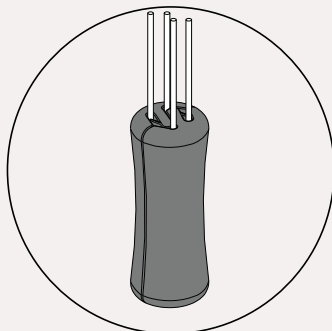

3. When all the cords are in the right position, press them together as shown in the figure.

### 3.7 Dust filters in ventilation hatches

Ventilation hatches are equipped with dust filters that should be cleaned at least twice yearly.

#### Ventilation hatch for outward-opening windows

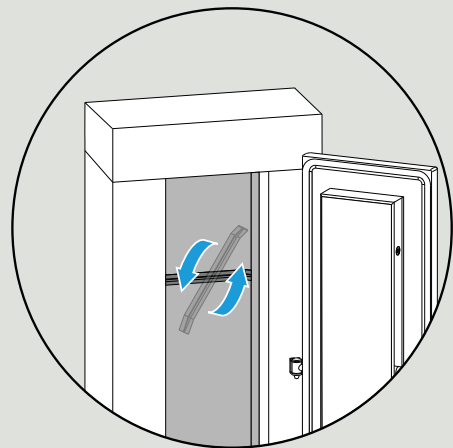

Open the ventilation hatch and turn the plastic clip by hand to release the dust filter. Wipe using a wet cloth or wash in soap and water. Allow to dry before reassembly.

Reassemble by snapping on the plastic clip so that the dust filter is squeezed to the aluminium plate.

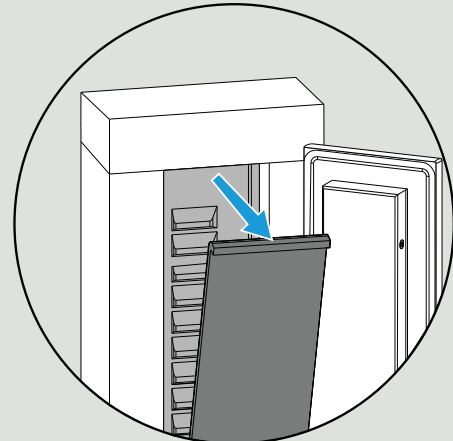

## Ventilation hatch for inward-opening windows



Open the ventilation hatch and remove the dust filter, which is attached using Velcro. Wipe using a wet cloth or wash in soap and water. Allow to dry before reassembly.

Reassemble by firmly pressing the dust filter against the Velcro.

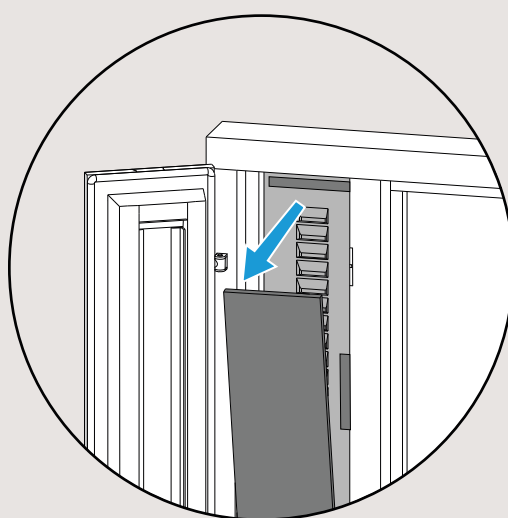

### 3.8 Mosquito nets

#### Mosquito nets for outward-opening products

On windows, the mosquito net is operated by pulling its lower part upwards or downwards. The mosquito net is automatically locked in the downwards position, released by pulling the metal buttons towards the centre and releasing the locking position. See figure below.

On French doors, the mosquito net is pulled sideways, it locks with a magnet when closed.



If necessary, wipe the net and dust filter strips using a slightly damp cloth, making sure the rails are free from dirt. Lubricate the rails once a year with lock oil or sewing machine oil.

## Mosquito nets inward opening

Dry the net using a slightly damp cloth.  
Vacuum the strips carefully to avoid scratching the aluminium.



When dismantling, the two plastic fittings are turned 90°. Now the fittings are once again spring-loaded.

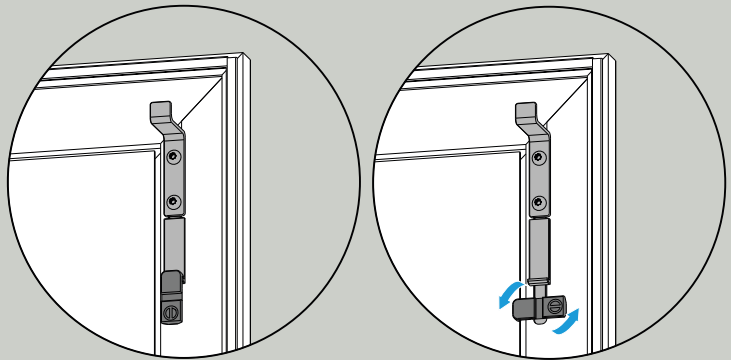

When dismantling, grab the handle at the centre of the frame and push the frame upwards to release the lower fittings, whereby the frame can be lowered from its position, tilted and lifted through the window opening.

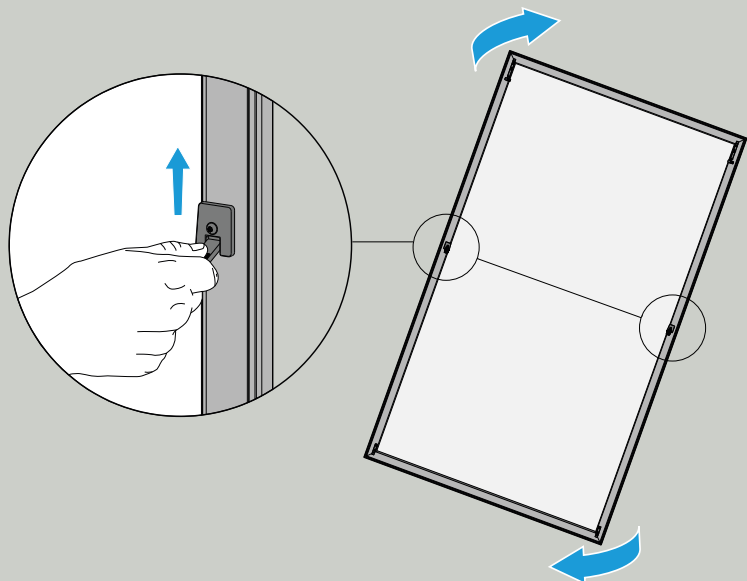

## 4. Warranty

The warranty protects against original manufacturing defects. It therefore does not cover transport damage or defects caused by, for example, incorrect storage, careless handling, incorrect installation or lack of maintenance. For the warranty to be valid, the product must be handled correctly according to our Installation Instructions and User and Maintenance Manual. See the website for warranty conditions.

